

USATE LE BUONE MANIGLIE

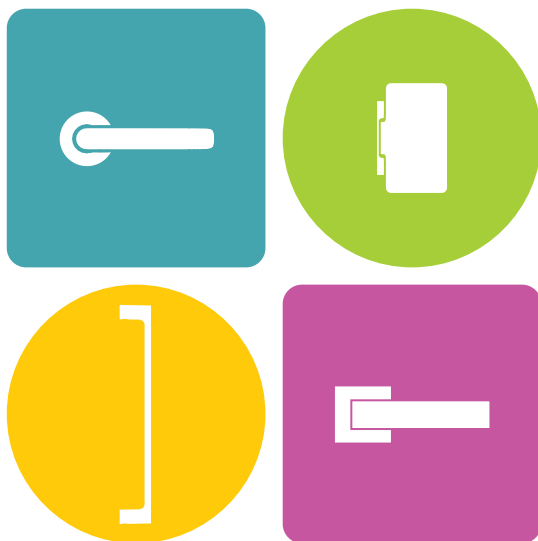



handles  
collection  
2 0 1 7

# Colombo Design: a family company.

## sempre vicini a te

Proprio come una famiglia accudisce i suoi membri con amore e dedizione, così Colombo Design cura i suoi prodotti, con gli stessi valori e le medesime tradizioni, per fare di ogni ambiente una casa, senza scendere mai a compromessi sull'autenticità. Un manifesto contemporaneo dell'essere creativi, curiosi e sperimentali.

## handles with care

Just like a family that handles its members with love and care, Colombo Design cares about its family of products and its production with the same values and traditions to make of any place a home, never accepting any compromise to quality and function, individuality and authenticity. Bonding heritage with creativity, curiosity and innovation.

Just like a family that handles its members with love and care, Colombo Design cares about its family of products and its production with the same values and traditions to make of any place a home, never accepting any compromise to quality and function, individuality and authenticity. Bonding heritage with creativity, curiosity and innovation.



# Colombo Design: our mission.

la qualità sensibile

**Intraprendere** un'impresa nel terzo millennio.

**Infondere** entusiasmo ai collaboratori, convinti che il fattore umano sia condizione essenziale al progresso aziendale.

**Produrre** secondo criteri di eccellenza nelle varie fasi di lavorazione per offrire prodotti garantiti.

**Rinnovare** costantemente impianti e procedure per precedere i rischi dell'obsolescenza. Questi i requisiti di Colombo Design; leader mondiale nella produzione di accessori bagno, presente in 93 paesi nel mondo attraverso una fitta rete di agenti e distributori. Una realtà solida, nata nel 1991, che si estende su una superficie di 100.000 mq, di cui 25.000 mq coperti, a Terno d'Isola in provincia di Bergamo.

discerning quality

**Creating** a business in the third millenium.

**Motivating** staff by recognising that human resources are essential to the company development;

**Achieving** manufacturing excellence at every stage of production so that products may be guaranteed;

**Continuously** updating machinery and manufacturing procedures in order to maintain quality levels in harmony with our environment. These are core principles of Colombo Design, world leader in the production of handles, present in 93 countries worldwide through an extensive network of agents and distributors. A solid reality, founded in 1991, based in Terno d'Isola, in the province of Bergamo, with an area of 100,000 square meters, of which 25,000 sqm are covered.

# Colombo Design network 93 countries



● Factory  
BERGAMO - ITALY

● Distributors

- |                           |               |                |
|---------------------------|---------------|----------------|
| ARGENTINA                 | JORDAN        | SWEDEN         |
| ARMENIA                   | KAZAKHSTAN    | SWITZERLAND    |
| AUSTRALIA                 | KENYA         | SYRIA          |
| AUSTRIA                   | KYRGYZSTAN    | THAILAND       |
| AZERBAIJAN                | KUWAIT        | TUNISIA        |
| BAHRAIN                   | LATVIA        | TURKEY         |
| BELARUS                   | LEBANON       | UAE            |
| BELGIUM                   | LIBYA         | UKRAINE        |
| BENIN                     | LITHUANIA     | UNITED KINGDOM |
| BOSNIA<br>and HERZEGOVINA | MACEDONIA     | USA            |
| BRAZIL                    | MALAYSIA      | UZBEKISTAN     |
| BULGARIA                  | MALTA         | VENEZUELA      |
| CANADA                    | MEXICO        | VIETNAM        |
| CHILE                     | MOLDOVA       | ZIMBABWE       |
| CHINA                     | MONACO        |                |
| COLOMBIA                  | MONTENEGRO    |                |
| CROATIA                   | MOROCCO       |                |
| CYPRUS                    | NETHERLANDS   |                |
| CZECH REPUBLIC            | NEW CALEDONIA |                |
| DENMARK                   | NEW ZEALAND   |                |
| ECUADOR                   | NIGERIA       |                |
| EGYPT                     | OMAN          |                |
| ESTONIA                   | PAKISTAN      |                |
| FINLAND                   | PANAMA        |                |
| FRANCE                    | PHILIPPINES   |                |
| GEORGIA                   | POLAND        |                |
| GERMANY                   | PORTUGAL      |                |
| GREECE                    | PUERTO RICO   |                |
| HONG KONG                 | QATAR         |                |
| HUNGARY                   | ROMANIA       |                |
| ICELAND                   | RUSSIA        |                |
| INDIA                     | SAUDI ARABIA  |                |
| INDONESIA                 | SENEGAL       |                |
| IRAN                      | SERBIA        |                |
| IRAQ                      | SINGAPORE     |                |
| IRELAND                   | SLOVAKIA      |                |
| ISRAEL                    | SLOVENIA      |                |
| IVORY COAST               | SOUTH AFRICA  |                |
| JAPAN                     | SOUTH KOREA   |                |
|                           | SPAIN         |                |





# Our Designers.



ACERBIS, Marco



ANGELETTI RUZZA DESIGN



ARCHITETTURA LABORATORIO



BARTOLI DESIGN



BETTONICA, Luta  
e LEONE, Giancarlo



CASTRIGNANO, Andrea



CLAESSON KOIVISTO RUNE



COLOMBO, Luca



DE LUCCHI, Michele



DI BLASI, Ottavio



GRIC, Konstantin



HASUIKE, Makio



KIMURA, Tomo



LUCHESE, Francesco



LOHMANN, Birgit



MASSAUD, Jean Marie



MEDA, Alberto



MESSINEDO e SETTIMELLI



**MODERNO DESIGN**  
CATTANEO, Paolo



MORRISON, Jasper



PININFARINA, Paolo



PIO e TITO TOSO lab



PIVA, Marco



RAGNI, Matteo



STUDIO KAIROS



STUDIO SPALVIERI / DEL CIOTTO

Progettare e costruire  
le maniglie più belle  
del mondo.

Designing and manufacturing  
the most beautiful handles in  
the world.

le collezioni  
the collections



alba	23
blazer	27
bold PT11	31
bold PT15	35
daytona	39
dea	43
drop	47
edo	51
electra	55
elle	59
ellesse	63
esprit	67
fedra	71
flessa	75
gala	79
gira	83
isy	87
lara	91
libra	95
lund	99
madi	103
meta	107
milla LC31	111
milla LC41	115
mixa	119
moon	123
olly	127
pegaso	131
prius	135
sirio	139
slim	143
spider MR11	147
spider MR15	151
star	155
tacta	159
tailla	163
taipan	167
talita	171
tecno	175
tender	179
tool	183
trama LC71	187
trama LC81	191
twitty	195
viola	199
wing	203
zelda	207

*Classic Line*



cameo	213
heidi	217
ida	221
peter	225
piuma	229

ROBOTECH®



mach	235
robot CD41	239
robot CD75	243
robodue	247
robotre	251
roboquattro	255
roboquattros	259

pomoli  
door knobs



bold PT15	264
cut	265
daytona	266
drop	267
etro	268
moon	269
push	270
robot	271
robot CD75	272
round	273
spider	274
square	275

maniglioni e battenti  
pulls and door knockers



daytona	278
elle	279
estro	280/1
flesso	282
logo	283
lund	284
noa	285/6
roboquattro	287
square	288
tender	289
wave	290
zen	291/2
blues	293
jazz	294
nice	295
piuma	296
robot	297
cloud	298
wind	299
am113-213y	300
id113-213y	301
id313-413y	302
lc113-213y	303
lc413-513y	304
cd113	305
cd213rs	306
flessum	307
toc-toc	307

maniglie incasso  
flush handles



slide	310
enter	311
open	312/3/4
open sq	315/6
cd111	317
cd211	317
cd311	318
cd511	318
cb111	319
id411	320
lc111	321

appenditutto  
coat hangers



alidé	324
club	325
forever	326
golf	327
hermitage	328
hook	329
khala	330
land	331
link	332
look	333
lulù	334
melo	335
nordic	336
over	337
plus	338
polo	339
portofino	340
time	341/2
trio	343

programma blindate  
armored door program



mostrine	346/7
inserti	348/9
pomolino	350
kit sr	351

complementi  
complements



dispositivi di	354/5
sicurezza	
dispositivi	356
antiefrazione	
fermaporta	357
chiavi	358
nottolini	359/60
libero/	361
occupato	
bocchette	362
tonde	
bocchette	363
quadre	
rosette	364
strette	
bocchette	365
strette	

# Our environmental approach.



**Lo sviluppo è sostenibile se soddisfa i bisogni delle generazioni presenti senza compromettere le possibilità per le generazioni future di soddisfare i propri bisogni.**

*Sustainable development is development that meets the needs of the present without compromising the ability of future generations to meet their own needs.*

*(Brundtland Report, United Nations, 1987)*



## E' TEMPO DI GREEN MADE IT'S GREEN MADE TIME

Green Made significa pensare, progettare e produrre in armonia con l'ambiente.

**Green Made: perché** In una economia globale assume un ruolo sempre più importante la protezione delle risorse disponibili ed in particolare lo studio degli aspetti ambientali legati alle diverse attività produttive. L'aumento dei consumi delle risorse non rinnovabili (i minerali ed i metalli come pure i combustibili fossili), dovuto alla costante crescita della popolazione mondiale, impone standards di produzione che privilegino la conservazione delle risorse disponibili.

I nostri processi produttivi sono frutto di una globale attenzione alla tutela dell'ambiente. La gestione accurata di questi processi ha portato, tra le altre cose, all'ottenimento della certificazione UNI EN ISO 14001 «Sistema di gestione ambientale certificato».

**Green Made: il valore** Ogni singola fase di progettazione e produzione è attentamente analizzata sotto il profilo dell'impatto ambientale ed ogni scelta successiva dettata dal raggiungimento degli obiettivi di eco compatibilità. Così durante la produzione vera e propria, saranno le più avanzate tecnologie appositamente sviluppate ed i più severi controlli, effettuati dal personale più qualificato, a garantire Green Made by Colombo Design: un prodotto nato con il pensiero costantemente rivolto all'ambiente.

«Green made» means thinking, developing and manufacturing in harmony with our environment.

**Green Made: why** Protecting our resources is more and more important in a global economy, and in particular paying attention to reflections of manufacturing onto the environment. Increase of consumptions of non-renewable resources (minerals, metals and fossil combustibles) due to increase of population, imposes manufacturing standards which privilege conservation of the available resources and raw materials. Our production processes are the result of a total attention to environmental protection. By the accurate management of these processes we obtained the UNI EN ISO 14001 certification «Certified environmental management system».

**Green Made: values** Each design and production step is carefully checked with regards to the environmental impact and each following decision is taken if our eco-compatibility objectives are fully reached.

This means that when we manufacture our products, the Green Made concept by Colombo Design will be assured by the advanced technologies and very strict controls carried out by a very highly qualified personnel, generating a product conceived constantly thinking of the environment.

# Our Certifications.



**Sistema di gestione certificato da ICIM**  
**Certified management system by ICIM**  
**UNI EN ISO 9001:2008**

Questa certificazione è valida per il seguente campo applicativo: Progettazione e fabbricazione di maniglie, complementi per arredamento e di accessori per l'arredo del bagno in materiali non ferrosi.

This certification is valid for the following application field: Design and manufacture of handles, furniture co-ordinated accessories and bathroom furniture accessories in non ferrous materials.



**Sistema di gestione certificato da ICIM**  
**Certified management system by ICIM**  
**UNI EN ISO 14001:2004**

Questa certificazione è valida per il seguente campo applicativo: Progettazione e fabbricazione di maniglie e complementi per arredamento in materiale non ferroso, accessori per l'arredo del bagno mediante le fasi di: pressofusione, burattatura, pulitura, galvanica, verniciatura, assemblaggio, confezionamento ed immagazzinamento.

This certification is valid for the following application field: Design and manufacture of non-ferrous handles and coordinated furniture accessories, bathroom furniture accessories by: die-casting, tumble finishing, polishing, electroplating, varnishing, assembling, packing and storing.



**Nuova certificazione europea per le maniglie**  
**New European certification for door furniture**  
**UNI EN 1906:2012**

La norma Europea UNI EN 1906:2012 stabilisce requisiti e metodi di prova per maniglie e pomoli.

Colombo Design ha conseguito, per tutti i suoi modelli, lusinghieri risultati tra i quali il più significativo è il "Grade 4" per la categoria d'uso: sinonimo di assoluta qualità e resistenza.

The European standard UNI EN 1906:2012 establishes requirements and test methods for lever handles and knobs.

Colombo Design achieved, for all of its models, excellent results between which the most significant is the "Grade 4" for the category of use: synonym of absolute quality and resistance.

# Colombo Design warranties



## HPS SISTEMA DI ALTA PROTEZIONE HPS HIGH PROTECTION SYSTEM

**TRATTAMENTO DI PROTEZIONE GARANTITO 30 ANNI** Quello utilizzato da Colombo Design è un processo di finitura mutuato dal settore dell'utensileria, in cui caratteristiche fisiche e meccaniche sono studiate per garantire prestazioni eccezionali di resistenza all'usura meccanica e al decadimento dovuto ad agenti ambientali e chimici, in cui il processo è stato messo a punto per garantire anche un notevole aspetto estetico, trasparenza e lucentezza fanno risaltare il design del prodotto. Tutti i prodotti trattati con il processo PVD, vengono preventivamente rivestiti con strati di rame, nichel e cromo per garantire un perfetto isolamento della materia prima sottostante. Trattamento con la garanzia di "30 anni" sulle finiture **Zirconium Gold** e **Zirconium Stainless-Steel**.

**PRESTAZIONI RIVESTIMENTO** I prodotti trattati con il processo PVD, garantiscono prestazioni di lunga durata. L'utilizzo di questi prodotti è particolarmente indicato nel caso di ambiente corrosivo, come aree marine ricche di salsedine o in zone soggette a piogge acide. L'utilizzo in pieno sole e le escursioni di temperatura non pregiudicano l'estetica del prodotto con viraggi di tonalità del colore. La durezza del rivestimento e il basso coefficiente di attrito superficiale garantiscono un'ottima resistenza ai graffi dovuti, per esempio, all'utilizzo di anelli. Eventuali ammaccature provocate da urti o colpi possono intaccare l'integrità e provocare il decadimento delle prestazioni del rivestimento.

**TREATMENT PROTECTION GUARANTEED 30 YEARS** Colombo Design uses a finishing process borrowed from the tools industry, where physical and mechanic features have to guarantee a very high performance as far as mechanic wear and decay due to environmental and chemical agents are concerned. This finishing process also guarantees a high level of design where transparency and brightness allow the product to show up. All PVD-treated products with High Protection System finishing are previously coated with layers of copper, nickel and chrome in order to guarantee the perfect insulation of the underlying raw material. Treatment with warranty of "30 years" on **Zirconium Gold** and **Zirconium Stainless-Steel** finishing.

**COATING PERFORMANCE** All PVD-treated products with High Protection System finishing guarantee better performance than any other type of coating, either galvanic or lacquer. The use of these products is strongly recommended in such places as high-salinity marine areas or areas subject to acid rains. The use in bright sunshine and temperature ranges does not cause color changes. The hardness of the coating and the low rate of surface friction ensure a very good resistance to scratches due to the use of rings (for example). Any dents due by hits or impact can spoil the surface and affect the coating performance.



## GARANZIA 10 ANNI GUARANTEED 10 YEARS

**TRATTAMENTO DI PROTEZIONE GARANTITO 10 ANNI** La lunga esperienza maturata nel settore dei trattamenti galvanici, unita alla scelta di prestare particolare attenzione alla qualità nei processi produttivi, consentono a Colombo Design di garantire le finiture dei suoi prodotti oltre la normale copertura prevista dalla legge. E' quindi con particolare orgoglio che offriamo ai nostri utenti la garanzia di "10 anni" sulle finiture **Chrome, Cromat, Oroplus, Vintage, Vintage Mat, Grafite e Grafite Mat**. Questo impegno di durata nel tempo del prodotto è la nostra forte ed alternativa risposta al consumismo «usa e getta», sinonimo di spreco ambientale e nemico della memoria collettiva, irrinunciabile valore di tutte le società.

Leggere tolleranze cromatiche, frutto del sofisticato processo PVD, nelle finiture **Vintage, Vintage Mat, Grafite e Grafite Mat** sono da considerarsi normali. Per un utilizzo ottimale del prodotto, ed ottemperare alle regole della garanzia: evitare l'impiego di sostanze solventi, abrasivi, alcool; rimuovere le eventuali tracce di sporco e polvere solo con un panno inumidito in acqua tiepida.

**TREATMENT PROTECTION GUARANTEED 10 YEARS** The long experience in the field of galvanic treatments, combined with the choice to pay special attention to the quality in production processes, enable Colombo Design to ensure the finishes of its products beyond the normal warranty provided by law.

It is therefore with great pleasure, we offer to our end-users the warranty of "10 years" on **Chrome, Cromat, Oroplus, Vintage, Vintage Mat, Graphite and Graphite Matt** finishing. This commitment of product durability is our strong and alternative response to consumerism «disposable», synonymous with environmental waste and enemy of collective memory, an essential value of all societies. Due to the high sophisticated PVD process slight color tolerances in the **Vintage, Vintage Mat, Graphite and Graphite Matt** finishes are to be considered normal. For maximum performance, kindly comply with the rules of warranty: do not use solvents, abrasives or alcohol; remove any traces of dirt and dust only with just a cloth damped in water.

# Colombo Design innovations & finishes



## SIX MILLIMETERS CONCEPT

Maniglie con rosetta e bocchetta bassa che non necessitano di lavorazioni aggiuntive sulla porta.  
Handles with slim rose and escutcheon. They don't need additional installation works on the door.

Modelli disponibili  
Available models

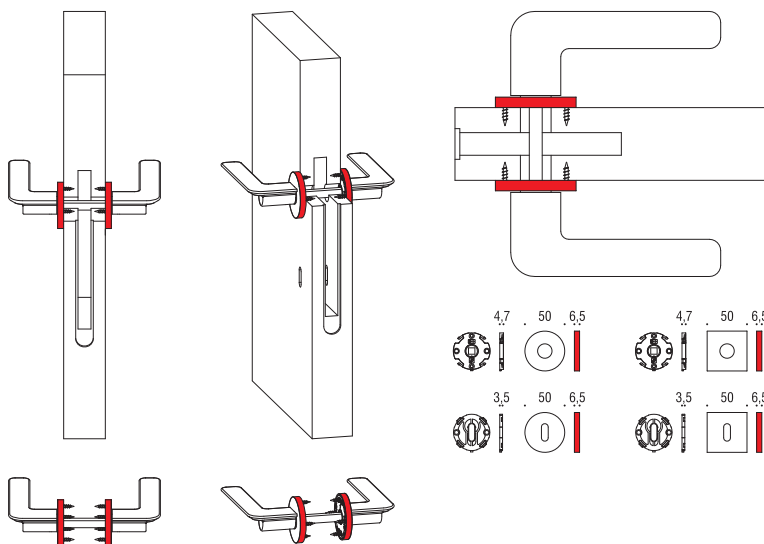















## ROBOTECH®

Robotech® contraddistingue una gamma di prodotti realizzata utilizzando alta tecnologia e massima automazione per ottenere eccellenza qualitativa e commerciale.

Robotech® is our mark for those products manufactured using high technologies and ultimate automation, to create quality and trading excellence.

## PROCESSO PRODUTTIVO PRODUCTION PROCESS

-  OTTONE . CROMALL® leghe metalliche con qualità certificata  
BRASS . CROMALL® metal alloys of certified quality
-  strato di pre-rame elettrodeposto  
first electroplated copper layer
-  secondo strato di rame elettrodeposto  
second electroplated copper layer
-  strato livellante di NICHEL elettrodeposto ad altissimo spessore  
very high electroplated NICKEL levelling layer
-  strato elettrodeposto di CROMO  - CROMAT   
electroplated CHROME - MAT CHROME
-  trattamento PVD solo per finiture HPS ZIRCONIUM GOLD   
HPS STAINLESS-STEEL  - OROPLUS  - VINTAGE   
VINTAGE MAT  - GRAFITE  - GRAFITE MAT   
PVD treatment applicable only on HPS ZIRCONIUM GOLD  
HPS STAINLESS-STEEL - OROPLUS - VINTAGE - VINTAGE MAT  
GRAPHITE and GRAPHITE MAT finishings

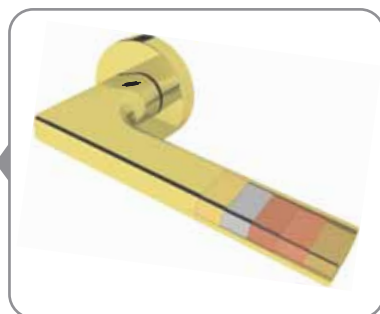

 stampaggio marchio di originalità  
trademark printing



Zirconium  
gold HPS



Oroplus



Oromat  
Matt gold



Zirconium  
stainless-steel HPS



Cromo  
Chrome



Cromat  
Matt chrome



Nikelmat  
Matt nickel



Vintage



Vintage Mat



Grafite  
Graphite



Grafite Mat  
Matt Graphite



Bronzo  
Bronze



Bronzo antico  
Antique bronze



Ottone antico  
Antique brass



Neromat  
Matt Black



Bianco  
White

# graphite & graphite mat

alba / elle / ellesse / lund





# *vintage* colours

il passato prossimo.  
reliving the past now.

Collezione di prodotti realizzati nella nuova finitura Vintage, versione lucida e satinata, che unisce passato e futuro.

Products realized in the new Vintage finish, available polished or satin, that unify past and future.

electra / fedra / gira / robo4s / viola





**LE COLLEZIONI**  
THE COLLECTIONS

LC 91  
**ALBA** 

Design: Luca Colombo

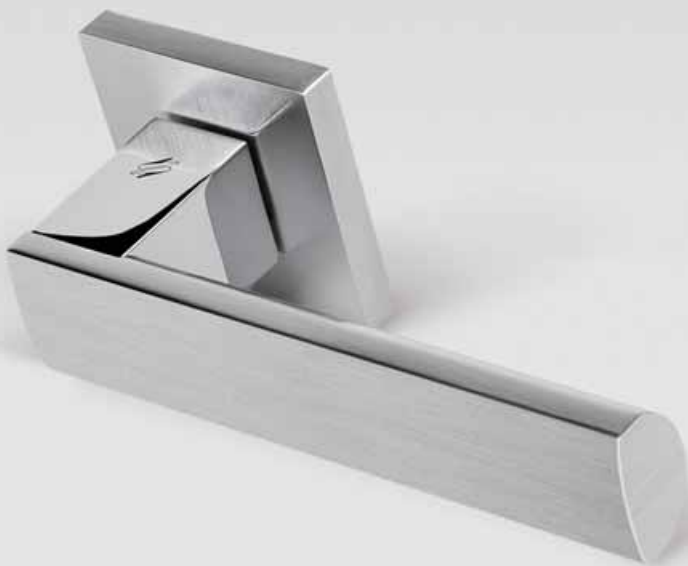
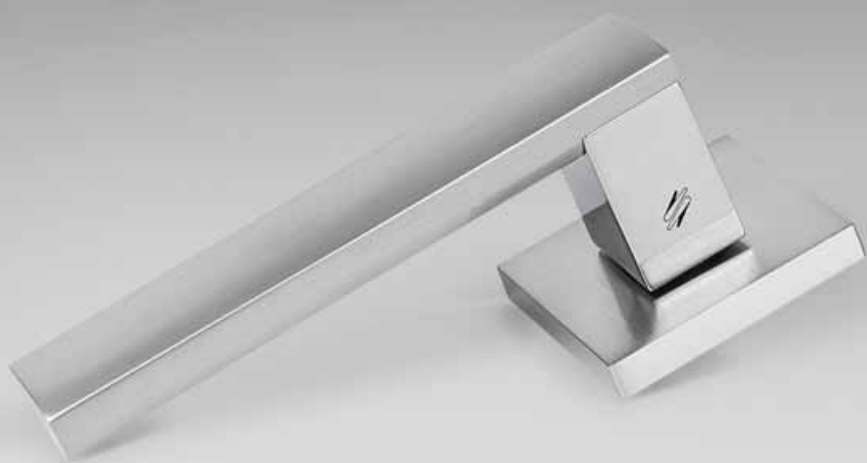

# alba

Design: Luca Colombo

Materiale: Ottone/Cromall®  
Material: Brass/Cromall®



six millimeters  
concept

maniglie con rosetta e bocchetta  
bassa che non necessitano di  
lavorazioni aggiuntive sulla porta,  
handles with slim rose and  
esutchcon don't need additional  
installation works on the door.



**CR/CM**  
Cromo/Cromat  
Chrome/Matt chrome



**GL/GM**  
Grafito/Grafito Mat  
Graphite/Matt graphite

## LC 91 R-RY

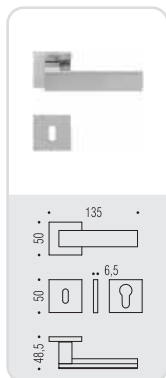

## FF 29 BZG 6/8

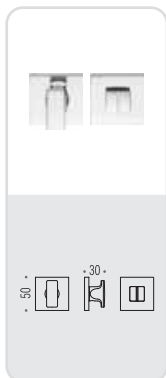

## LC 92 IM

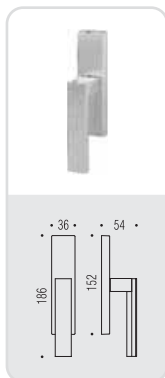

## LC 92 DK/SM

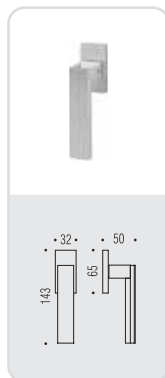



FL 11

# BLAZER



Design: Francesco Lucchese





# blazer

Design: Francesco Lucchese

Materiale: Ottone  
Material: Brass



**HPS**  
Zirconium gold HPS



**OL**  
Oroplus



**HPS/1**  
Zirconium stainless-steel HPS



**CM**  
Cromat  
Matt chrome

## FL 11 R-RY

HPS OL HPS1 CM

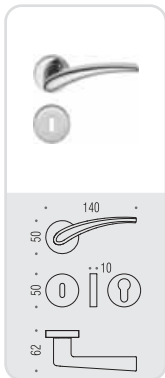

## CD 49 BZG G 6/8

HPS OL HPS1 CM



## FL 12 IM

HPS OL HPS1 CM

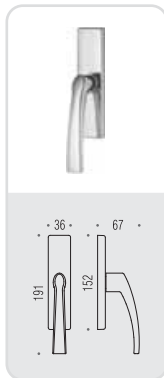

## FL 12 DK/SM

HPS OL HPS1 CM

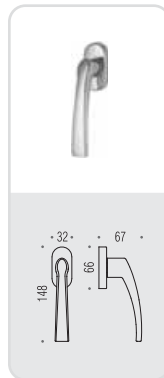



**PT 11**  
**BOLD** 

Design: Pio e Tito Toso lab



# bold

Design: Pio e Tito Toso lab

Materiale: Ottone  
Material: Brass



**CR**  
Cromo  
Chrome



**CM**  
Cromat  
Matt chrome

## PT 11 R-RY

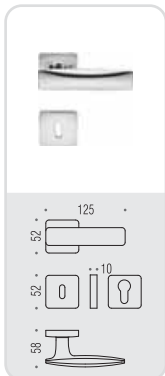

## PT 19 BZG 6/8

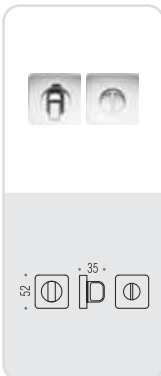

## PT 12 IM

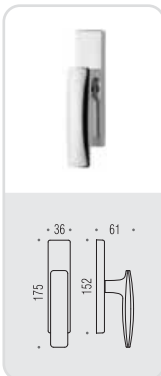

## PT 12 DK/SM

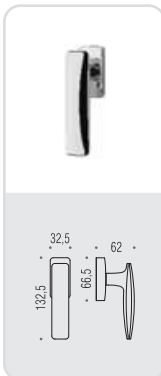



PT 15

# BOLD



Design: Pio e Tito Toso lab





# bold

Design: Pio e Tito Toso lab

Materiale: Ottone  
Material: Brass



**CR**  
Cromo  
Chrome



**CM**  
Cromat  
Matt chrome

## PT 15 R-RY

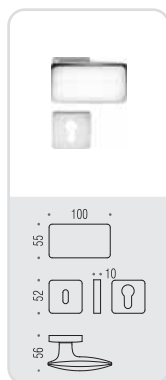

## PT 19 BZG 6/8





PF 11

# DAYTONA

Design: *pininfarina*





# daytona

Design: *piiniferina*

Materiale: Ottone  
Material: Brass



**OL**  
Oropius



**CM**  
Cromat  
Matt chrome

## PF 11 R-RY

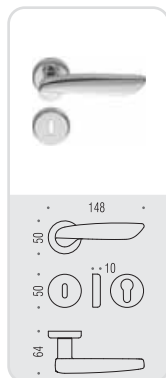

## CD 69 BZG G 6/8



## PF 12 IM

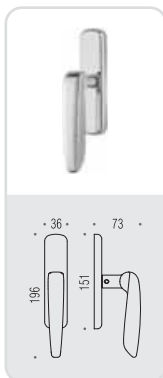

## PF 12 DK/SM

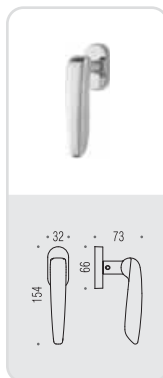



FF 21  
**DEA**   
Design: Pio e Tito Toso lab





# dea

Design: Pio e Tito Toso lab

Materiale: Ottone  
Material: Brass



six millimeters  
concept

maniglie con rosetta e bocchetta  
bassa che non necessitano di  
lavorazioni aggiuntive sulla porta,  
handles with slim rose and  
escutcheon don't need additional  
installation works on the door.



**CR**  
Cromo  
Chrome



**CM**  
Cromat  
Matt chrome

## FF 21 R-RY

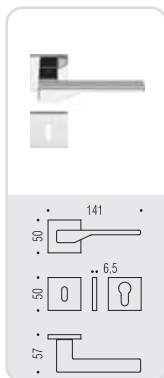

## FF 29 BZG 6/8

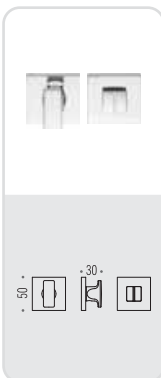

## FF 22 IM

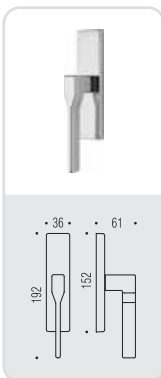

## FF 22 DK/SM

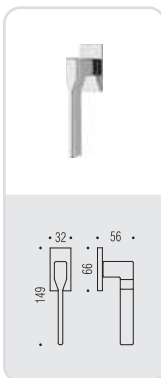



LC 45  
**DROP** ○

Design: Luca Colombo



# drop

Design: Luca Colombo

Materiale: Ottone  
Material: Brass



**HPS**  
Zirconium gold HPS



**CR**  
Cromo  
Chrome



**CM**  
Cromat  
Matt chrome



**BR**  
Bronzo  
Bronze

## LC 45 R-RY

HPS CR CM BR

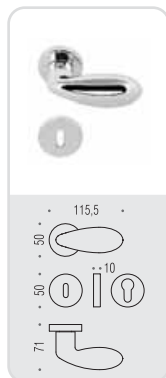

## CD 49 BZG G 6/8

HPS CR CM BR

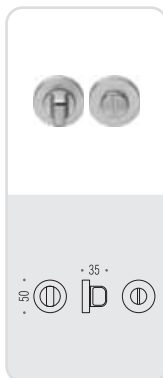



MH 11  
**EDO** ○  
Design: Makio Hasuike





# edo

Design: Makio Hasuike

Materiale: Ottone  
Material: Brass



**OL**  
Oroplus



**CM**  
Cromat  
Matt chrome

## MH 11 R-RY

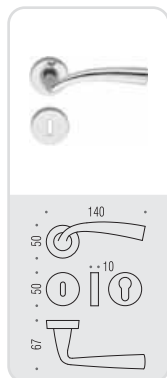

## CD 49 BZG G 6/8



## MH 12 IM

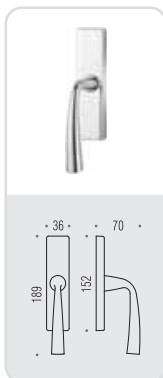

## MH 12 DK/SM

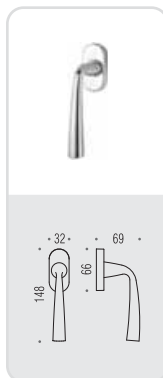



**MS 11**  
**ELECTRA** 

Design: Messineo e Settimelli



# electra

Design: Messineo e Settimelli

Materiale: Cromall®  
Material: Cromall®



six millimeters  
concept

maniglie con rosetta e bocchetta  
bassa che non necessitano di  
lavorazioni aggiuntive sulla porta,  
handles with slim rose and  
escutcheon don't need additional  
installation works on the door.



**CR**  
Cromo  
Chrome



**CM**  
Cromat  
Matt chrome



**VL**  
Vintage

*vintage*



**VM**  
Vintage Mat

*vintage*

## MS 11 R-RY

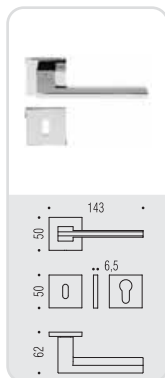

## FF 29 BZG 6/8

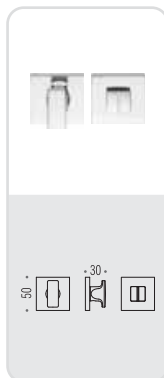

## MS 12 IM

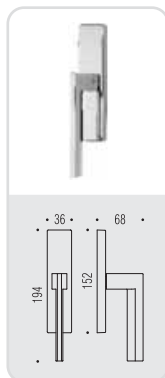

## MS 12 DK/SM

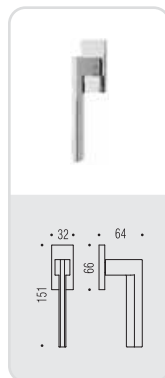



**BD 11**  
**ELLE** ○  
Design: Bartoli Design





# elle

Design: Bartoli Design

Materiale: Cromal®/Ottone  
Material: Cromal®, Brass



**CR**  
Cromo  
Chrome



**GL**  
Grafite  
Graphite



**CM**  
Cromat  
Matt chrome



**GM**  
Grafite Mat  
Matt graphite

VERSIONE STANDARD  
STANDARD VERSION

**BD 11 R-RY**

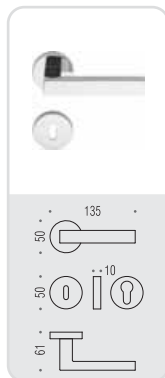

**CD 49 BZG G 6/8**



**BD 12 IM**

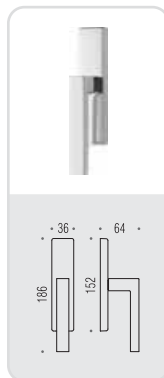

**BD 12 DK/SM**

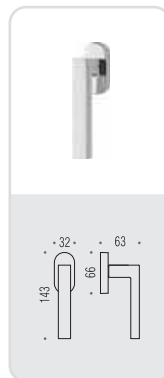

VARIANTI DISPONIBILI  
ALSO AVAILABLE



**six millimeters  
concept**  
maniglie con rosetta e bocchetta  
bassa che non necessitano di  
lavorazioni aggiuntive sulla porta.  
handles with slim rose and  
escutcheon don't need additional  
installation works on the door.

**BD 11 RF-RYF**

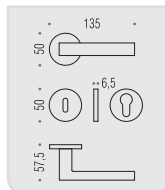

**FF 19 BZG 6/8**



**BD 12 DKF/SM**

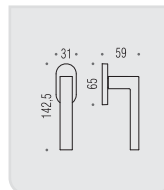

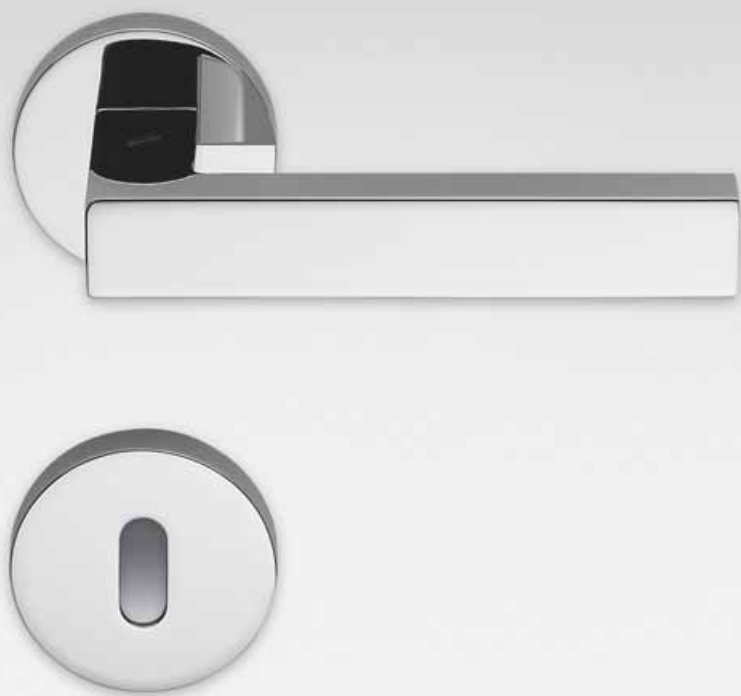

**BD 21**  
**ELLESSE** 

Design: Bartoli Design



# ellesse

Design: Bartoli Design

Materiale: Cromal®/Ottone  
Material: Cromal®, Brass



**CR**  
Cromo  
Chrome



**GL**  
Grafite  
Graphite



**CM**  
Cromat  
Matt chrome



**GM**  
Grafite Mat  
Matt graphite

VERSIONE STANDARD  
STANDARD VERSION

**BD 21 R-RY**

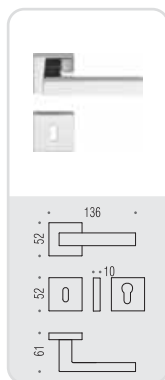

**MM 29 BZG 6/8**



**BD 12 IM**

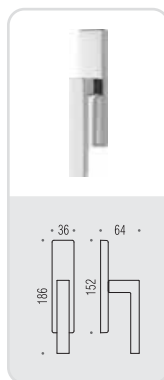

**BD 22 DK/SM**

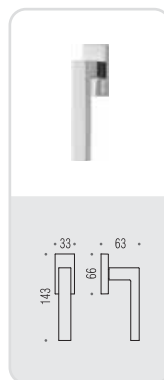

VARIANTI DISPONIBILI  
ALSO AVAILABLE

**BD 21 R-F-RYF**

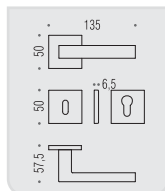

**FF 29 BZG 6/8**

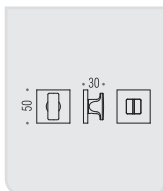

**BD 22 DKF/SM**

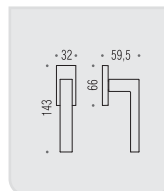

**six millimeters  
concept**

maniglie con rosetta e bocchetta  
bassa che non necessitano di  
lavorazioni aggiuntive sulla porta.  
handles with slim rose and  
escutcheon don't need additional  
installation works on the door.

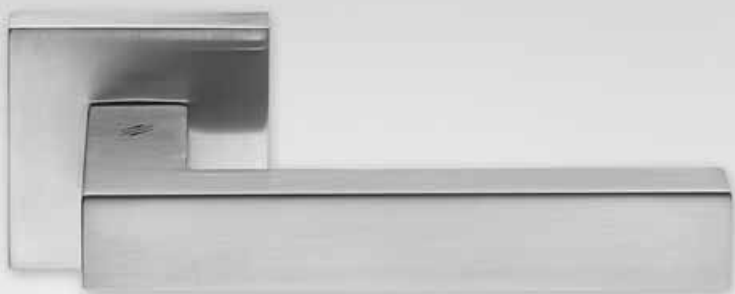

BT 11

# ESPRIT



Design: Birgit Lohmann



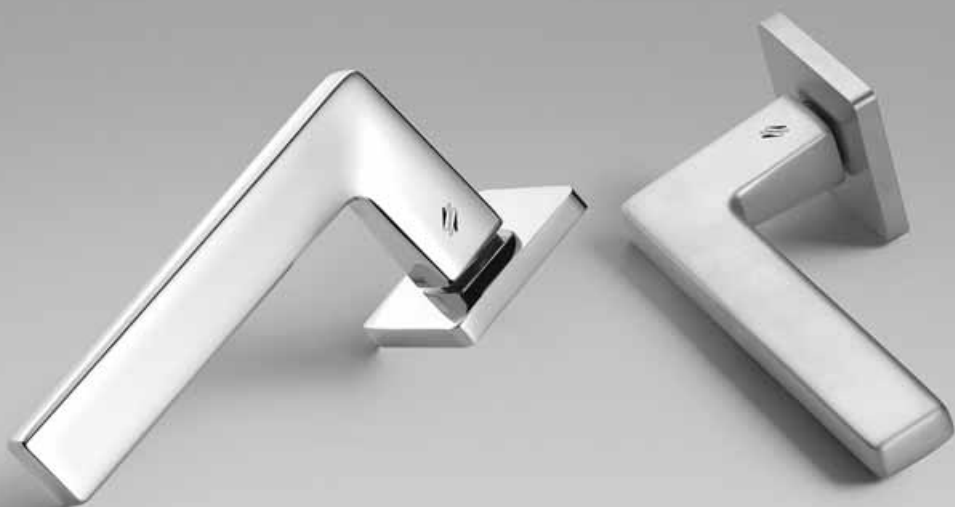

# esprit

Design: Birgit Lohmann

Materiale: Ottone

Material: Brass



six millimeters  
concept

maniglie con rosetta e bocchetta  
bassa che non necessitano di  
lavorazioni aggiuntive sulla porta,  
handles with slim rose and  
escutcheon don't need additional  
installation works on the door.



**HPS/1**  
Zirconium stainless-steel HPS



**CR**  
Cromo  
Chrome



**CM**  
Cromat  
Matt chrome

## BT 11 R-RY

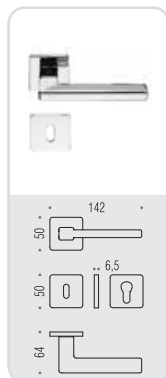

## BT 19 BZG 6/8

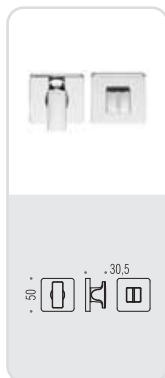

## BT 12 IM

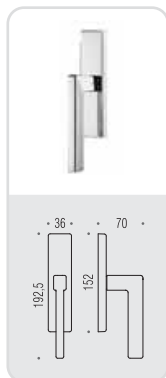

## BT 12 DK/SM

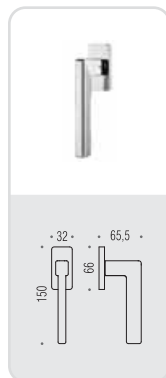



AC 11

# FEDRA



Design: Andrea Castrignano



# fedra

Design: Andrea Castrignano

Materiale: Ottone  
Material: Brass



six millimeters  
concept

maniglie con rosetta e bocchetta  
bassa che non necessitano di  
lavorazioni aggiuntive sulla porta,  
handles with slim rose and  
escutcheon don't need additional  
installation works on the door.



**OL**  
Oroplus



**CR**  
Cromo  
Chrome



**CM**  
Cromat  
Matt chrome



**VL**  
Vintage

*vintage*



**VM**  
Vintage Mat

*vintage*

## AC 11 R-RY

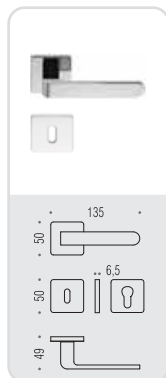

## BT 19 BZG 6/8

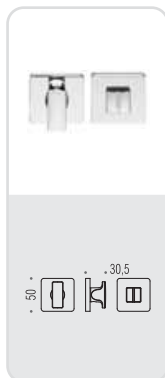

## AC 12 IM

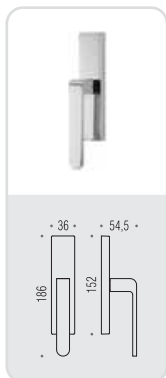

## AC 12 DK/SM

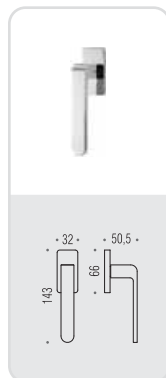



**CB 51**  
**FLESSA** ○

Design: Carlo Bartoli





# flessa

Design: Carlo Bartoli

Materiale: Ottone  
Material: Brass



**HPS**  
Zirconium gold HPS



**OL**  
Oroplus



**CM**  
Cromat  
Matt chrome



**NI**  
Nikelmat  
Matt nickel

## CB 51 R-RY

HPS OL CM NI

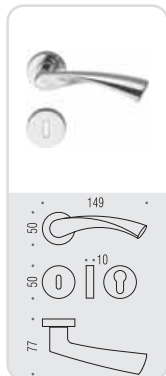

## CD 49 BZG G 6/8

HPS OL CM NI



## CB 52 M

HPS OL CM NI

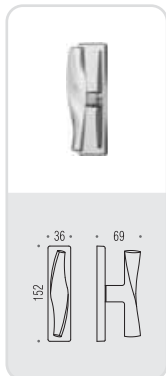

## CB 52 DK/SM DX-SX

HPS OL CM NI





GR 11  
**GAIA** ○

Design: Giulio Ripamonti



# gaia

Design: Giulio Ripamonti

Materiale: Ottone  
Material: Brass



**OL**  
Oroplus



**CR**  
Cromo  
Chrome



**CM**  
Cromat  
Matt chrome

## GR 11 R-RY

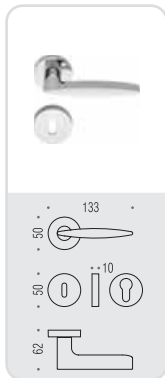

## CD 49 BZG G 6/8



## GR 12 IM

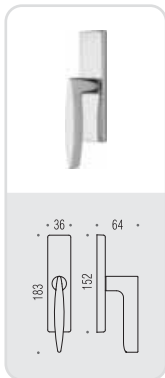

## GR 12 DK/SM

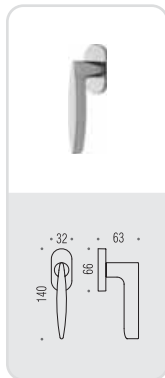



JM 11  
**GIRA** ○  
Design: Jasper Morrison





# gira

Design: Jasper Morrison

Materiale: Ottone  
Material: Brass



**OL**  
Oroplus



**CR**  
Cromo  
Chrome



**HPS/1**  
Zirconium stainless-steel HPS



**CM**  
Cromat  
Matt chrome



**VL**  
Vintage

*vintage*



**VM**  
Vintage Mat

*vintage*

## JM 11 R-RY

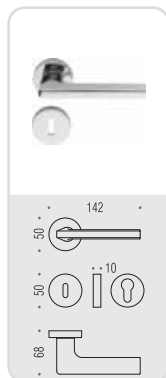

## CD 49 BZG G 6/8

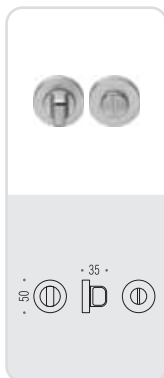

## JM 12 IM

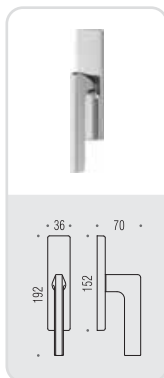

## JM 12 DK/SM

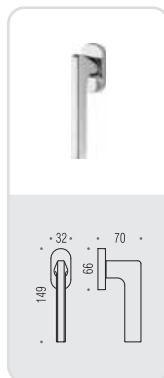



BL 11  
**ISY** 

Design: Luta Bettonica  
e Giancarlo Leone



# isy

Design: Luta Bettonica e Giancarlo Leone

Materiale: Ottone  
Material: Brass



**CR**  
Cromo  
Chrome



**CM**  
Cromat  
Matt chrome

VERSIONE STANDARD  
STANDARD VERSION

**BL 11 R-RY**

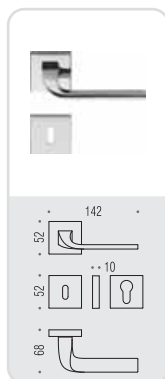

**MM 29 BZG 6/8**

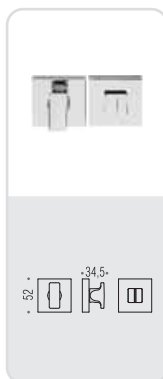

**BL 12 IM**

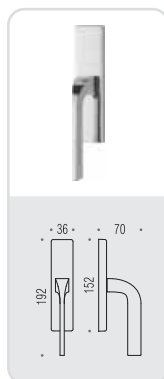

**BL 12 DK/SM**

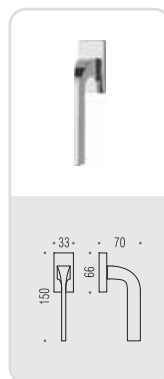

VARIANTI DISPONIBILI  
ALSO AVAILABLE

**BL 11 RF-RYF**

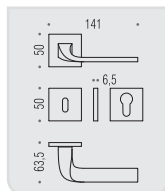

**FF 29 BZG 6/8**

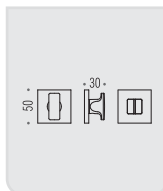

**BL 12 DKF/SM**

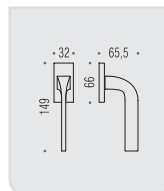

**six millimeters  
concept**  
maniglie con rosetta e bocchetta  
bassa che non necessitano di  
lavorazioni aggiuntive sulla porta.  
handles with slim rose and  
escutcheon don't need additional  
installation works on the door.



**CB 71**  
**LARA** ○

Design: Carlo Bartoli





# lara

Design: Carlo Bartoli

Materiale: Ottone  
Material: Brass



**HPS**  
Zirconium gold HPS



**OL**  
Oropius



**OM**  
Oromat  
Matt gold



**CM**  
Cromat  
Matt chrome



**NI**  
Nikelmat  
Matt nickel

## CB 71 R-RY

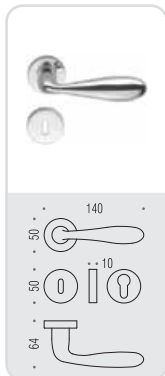

## CD 49 BZG G 6/8



## CB 72 IM

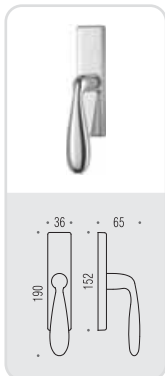

## CB 72 DK/SM

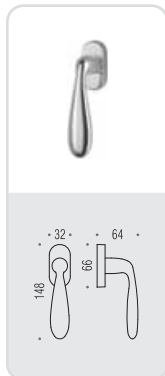



SK 21  
**LIBRA** ○

Design: Studio Kairos



# libra

Design: Studio Kairos

Materiale: Ottone  
Material: Brass



**OL**  
Oroplus



**CR**  
Cromo  
Chrome

## SK 21 R-RY

OL CR

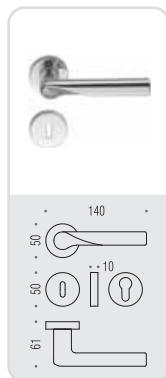

## CD 49 BZG G 6/8

OL CR



## SK 22 M

OL CR

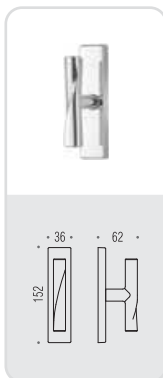

## SK 22 DK/SM

OL CR

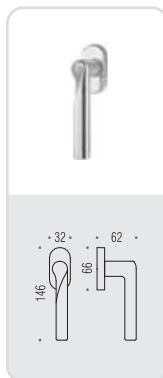



SE 11  
**LUND** ○

Design: Claesson Koivisto Rune





# lund

Design: Claesson Koivisto Rune

Materiale: Ottone  
Material: Brass



six millimeters  
concept

maniglie con rosetta e bocchetta  
bassa che non necessitano di  
lavorazioni aggiuntive sulla porta,  
handles with slim rose and  
essacheon don't need additional  
installation works on the door.



**CR**  
Cromo  
Chrome



**CM**  
Cromat  
Matt chrome



**GL**  
Grafito  
Graphite



**GM**  
Grafito Mat  
Matt graphite

## SE 11 R-RY

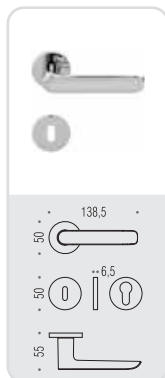

## SE 19 BZG 6/8



## SE 12 IM

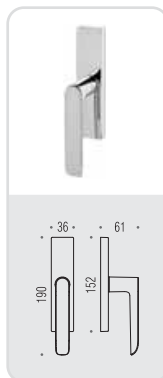

## SE 12 DK/SM

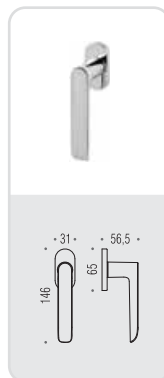



AM 31  
**MADI** ○

Design: Alberto Meda



# madi

Design: Alberto Meda

Materiale: Ottone  
Material: Brass



**Selezione d'onore  
Compasso d'Oro  
ADI 1998**



**OL**  
Oroplus



**OM**  
Oromat  
Matt gold



**CM**  
Cromat  
Matt chrome

## AM 31 R-RY

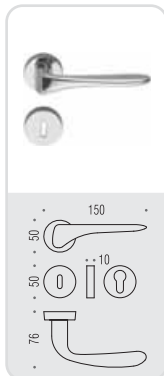

## CD 49 BZG G 6/8



## AM 32 M

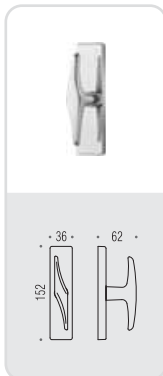

## AM 32 DK/SM DX-SX





**KG 11**  
**META** ○

Design: Konstantin Grcic





# meta

Design: Konstantin Grcic

Materiale: Ottone  
Material: Brass



**CR**  
Cromo  
Chrome



**CM**  
Cromat  
Matt chrome

## KG 11 R-RY

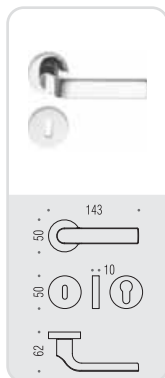

## CD 49 BZG G 6/8



## KG 12 IM

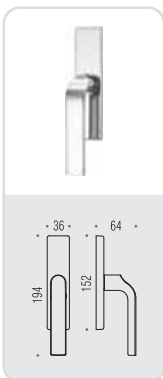

## KG 12 DK/SM

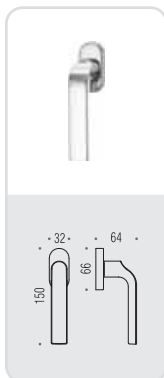



LC 31  
**MILLA** ○

Design: Luca Colombo



# milla

Design: Luca Colombo

Materiale: Cromall®  
Material: Cromall®



**OL/OM**  
Oroplus/Cromat  
Oroplus/Matt gold



**CR/CM**  
Cromo/Cromat  
Chrome/Matt chrome

## LC 31 R-RY

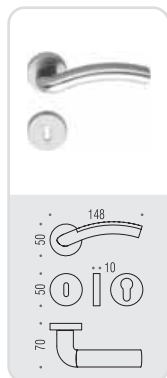

## CD 49 BZG G 6/8



## LC 32 IM

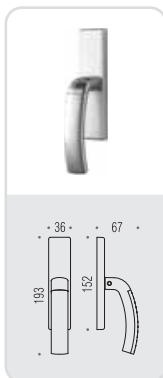

## LC 32 DK/SM

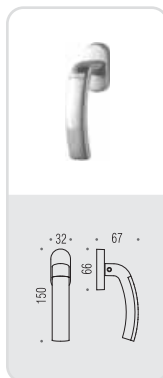



LC 41  
**MILLA** ○

Design: Luca Colombo





# milla

Design: Luca Colombo

Materiale: Cromall®  
Material: Cromall®



**OL/OM**  
Oroplus/Cromat  
Oroplus/Matt gold



**CR/CM**  
Cromo/Cromat  
Chrome/Matt chrome

## LC 41 R-RY

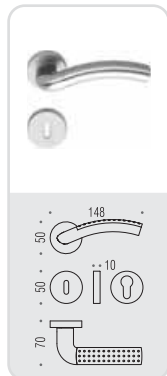

## CD 49 BZG G 6/8



## LC 42 IM

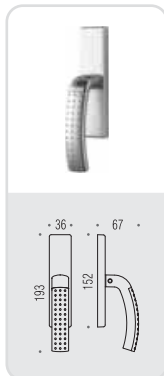

## LC 42 DK/SM





CB 21  
**MIXA** ○

Design: Carlo Bartoli



# mixa

Design: Carlo Bartoli

Materiale: Ottone  
Material: Brass



**OL/OM**  
Oroplus/Oromat  
Oroplus/Matt gold



**CR/CM**  
Cromo/Cromat  
Chrome/Matt chrome

## CB 21 R-RY

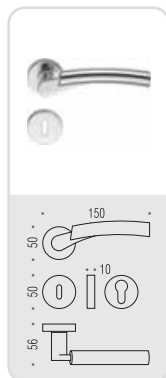

## CD 49 BZG G 6/8



## CB 22 M

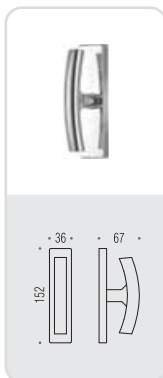

## CB 22 DK/SM DX-SX

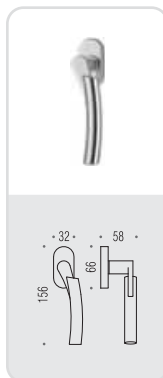



**BD 15**  
**MOON** ○

Design: Bartoli Design





# moon

Design: Bartoli Design

Materiale: Ottone  
Material: Brass



**HPS**  
Zirconium gold HPS



**CR**  
Cromo  
Chrome



**CM**  
Cromat  
Matt chrome

## BD 15 R-RY

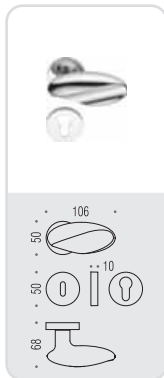

## CD 49 BZG G 6/8





LC 61  
**OLLY** ○

Design: Luca Colombo



# olly

Design: Luca Colombo

Materiale: Ottone  
Material: Brass



**OL**  
Oroplus



**CR**  
Cromo  
Chrome



**CM**  
Cromat  
Matt chrome

## LC 61 R-RY

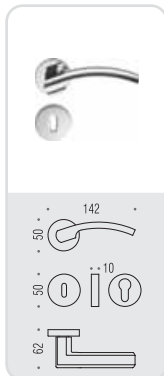

## CD 49 BZG G 6/8

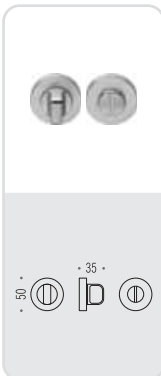

## LC 62 IM

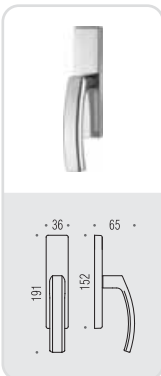

## LC 62 DK/SM

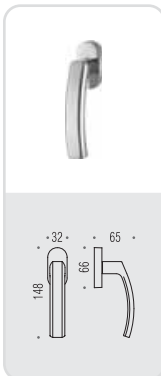



AM 11  
**PEGASO** ○

Design: Alberto Meda





# pegaso

Design: Alberto Meda

Materiale: Ottone  
Material: Brass



**CR**  
Cromo  
Chrome



**CM**  
Cromat  
Matt chrome

## AM 11 R-RY

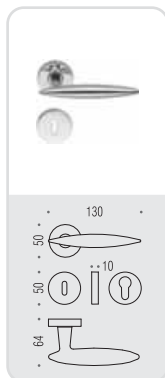

## CD 49 BZG G 6/8



## AM 12 M

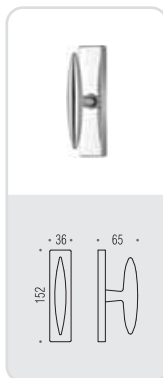

## AM 12 DK/SM

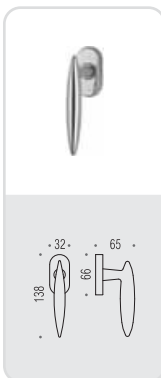



MA 11  
**PRIUS** □

Design: Marco Acerbis



# prius

Design: Marco Acerbis

Materiale: Ottone  
Material: Brass



Selezione d'onore  
Compasso d'Oro  
ADI 2008



**CR**  
Cromo  
Chrome



**CM**  
Cromat  
Matt chrome

## MA 11 R-RY

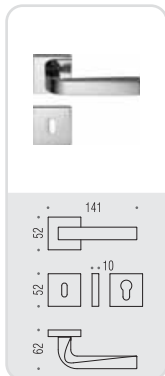

## MM 29 BZG 6/8



## MA 12 IM

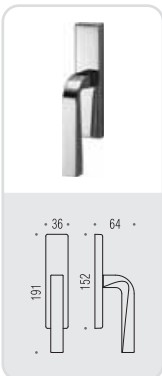

## MA 12 DK/SM

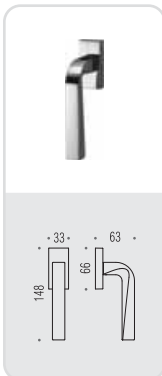



CD 11

# SIRIO



Design: Colombo Design





# sirio

Design: Colombo Design

Materiale: Ottone  
Material: Brass



**OL**  
Oroplus



**CR**  
Cromo  
Chrome



**CM**  
Cromat  
Matt chrome

## CD 11 R-RY

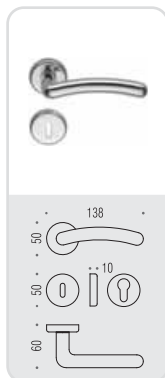

## CD 69 BZG G 6/8



## CD 12 M

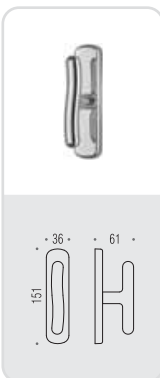

## CD 12 DK/SM DX-SX





FF 11  
**SLIM** ○

Design: Studio Spalvieri / Del Clotto



# slim

Design: Studio Spalvieri / Del Ciotto

Materiale: Ottone  
Material: Brass



six millimeters  
concept

maniglie con rosetta e bocchetta  
bassa che non necessitano di  
lavorazioni aggiuntive sulla porta,  
handles with slim rose and  
escutcheon don't need additional  
installation works on the door.



**CR**  
Cromo  
Chrome



**CM**  
Cromat  
Matt chrome

## FF 11 R-RY

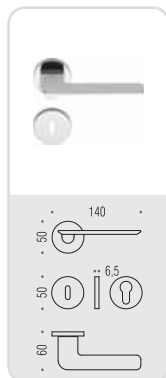

## FF 19 BZG 6/8

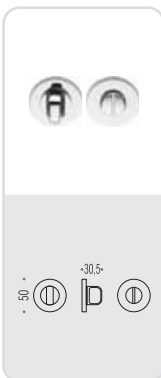

## FF 12 IM

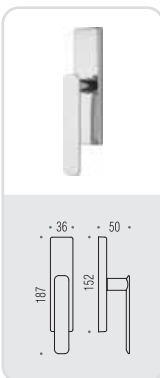

## FF 12 DK/SM

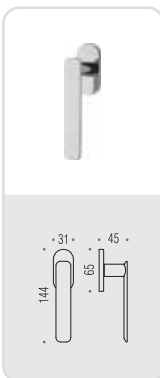



MR 11

# SPIDER



Design: Matteo Ragni





# spider

Design: Matteo Ragni

Materiale: Ottone e Tecnowood  
Material: Brass and Tecnowood

Le differenze di venatura e colore che si riscontrano sul particolare, sono tipiche del legno  
Wood grains and colors differences are the characteristics of the wood



**CR**  
Cromo  
Chrome



**CM**  
Cromat  
Matt chrome



**CM/RO**  
Cromat/Rovere  
Matt chrome/Oak wood



**CM/EB**  
Cromat/Ebano  
Matt chrome/Ebony wood

## MR 11 R-RY

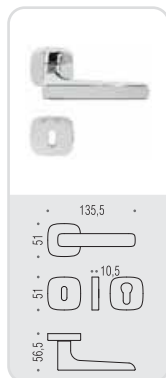

## MR 29 BZG G 6/8



## MR 12 IM

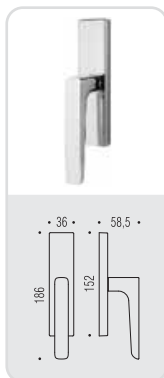

## MR 12 DK/SM

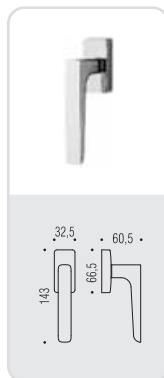



MR 15  
**SPIDER** 

Design: Matteo Ragni



# spider

Design: Matteo Ragni

Materiale: Ottone  
Material: Brass



**CR**  
Cromo  
Chrome



**CM**  
Cromat  
Matt chrome

## MR 15 R-RY

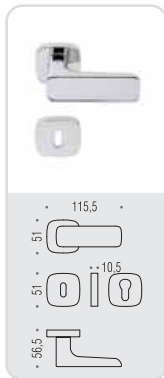

## MR 29 BZG G 6/8





CD 01

# STAR

Design: Colombo Design







# star

Design: Colombo Design

Materiale: Ottone  
Material: Brass



**OL**  
Oroplus



**CM**  
Cromat  
Matt chrome

## CD 01 R-RY

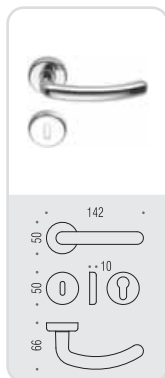

## CD 69 BZG G 6/8



## CD 02 IM

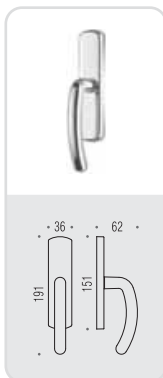

## CD 02 DK/SM





**CB 11**  
**TACTA** ○

Design: Carlo Bartoli



# tacta

Design: Carlo Bartoli

Materiale: Ottone e legno massello  
Material: Brass and genuine wood

Le differenze di venatura e colore che si riscontrano sul particolare in legno, sono dovute esclusivamente all'utilizzo di masselli  
Grain and colour differences you notice on the piece are natural characteristics of the genuine wood



**NI/EM**  
Nikelmat/Ebano makassar  
Matt nickel/Makassar ebony



**NI/PE**  
Nikelmat/Pero  
Matt nickel/Pear wood

## CB 11 R-RY

## CD 39 BZG 6/8

## CB 12 IM

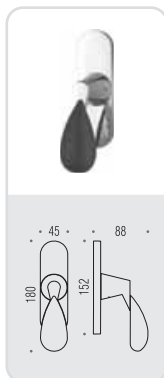
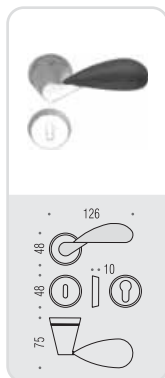



LC 51  
**TAILLA** ○

Design: Luca Colombo





# tailla

Design: Luca Colombo

Materiale: Cromall®  
Material: Cromall®



**OL/OM**  
Oroplus/Cromat  
Oroplus/Matt gold



**CR/CM**  
Cromo/Cromat  
Chrome/Matt chrome

## LC 51 R-RY

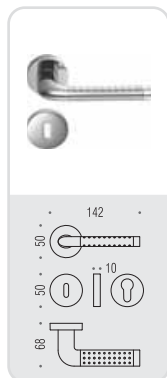

## CD 49 BZG G 6/8



## LC 52 IM

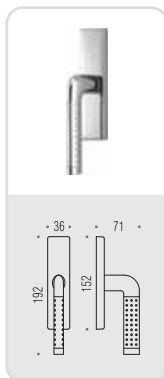

## LC 52 DK/SM

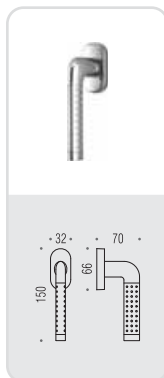



LC 11  
**TAIPAN** ○

Design: Luca Colombo



# taipan

Design: Luca Colombo

Materiale: Cromall®  
Material: Cromall®



**OL/OM**  
Oroplus/Oromat  
Oroplus/Matt gold



**CR/CM**  
Cromo/Cromat  
Chrome/Matt chrome

## LC 11 R-RY

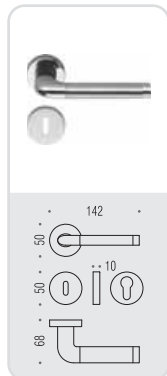

## CD 49 BZG G 6/8



## LC 12 IM

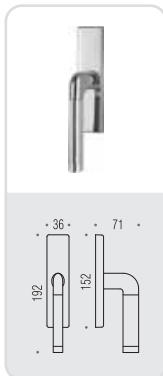

## LC 12 DK/SM

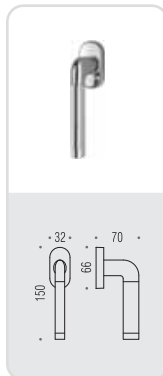



LC 21  
**TALITA** ○

Design: Luca Colombo





# talita

Design: Luca Colombo

Materiale: Cromall®  
Material: Cromall®



**OL/OM**  
Oroplus/Cromat  
Oroplus/Matt gold



**CM/CR**  
Cromat/Cromo  
Matt chrome/Chrome

## LC 21 R-RY

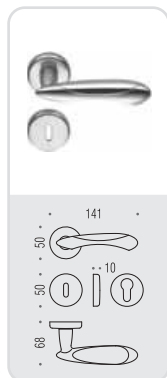

## CD 69 BZG G 6/8



## LC 22 IM

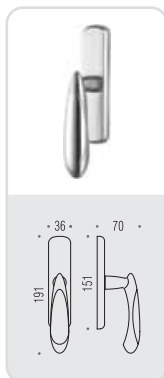

## LC 22 DK/SM

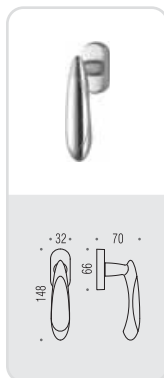



MO 11

# TECNO

Design:  DESIGN



# tecno

Design: **mimo**DESIGN

Materiale: Cromal®  
Material: Cromal®



**six millimeters  
concept**

maniglie con rosetta e bocchetta  
bassa che non necessitano di  
lavorazioni aggiuntive sulla porta,  
handles with slim rose and  
essucheon don't need additional  
installation works on the door.



**CM/CMQ**  
Cromat/Carbonium  
Matt chrome/Carbonium



**CM/CR**  
Cromat/Cromo  
Matt chrome/Chrome

## MO 11 R-RY

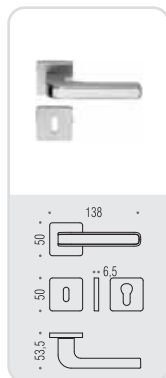

## BT 19 BZG 6/8

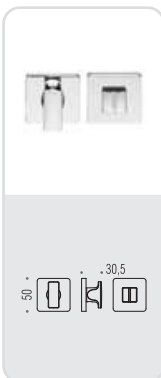

## MO 12 IM

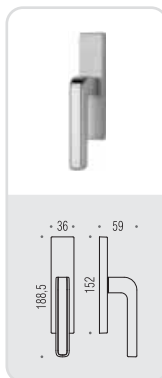

## MO 12 DK/SM

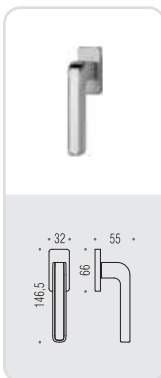



**MG 11**  
**TENDER** ○

Design: Architettura Laboratorio





# tender

Design: Architettura Laboratorio

Materiale: Ottone  
Material: Brass



**OL**  
Oroplus



**CM**  
Cromat  
Matt chrome



**NI**  
Nikelmat  
Matt nickel

## MG 11 R-RY

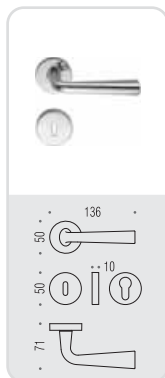

## CD 49 BZG G 6/8

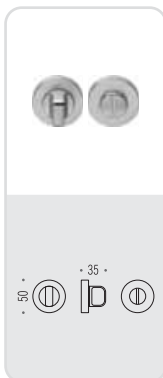

## MG 12 IM

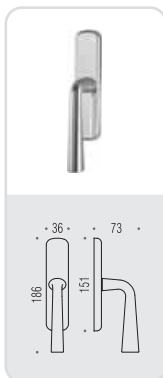

## MG 12 DK/SM



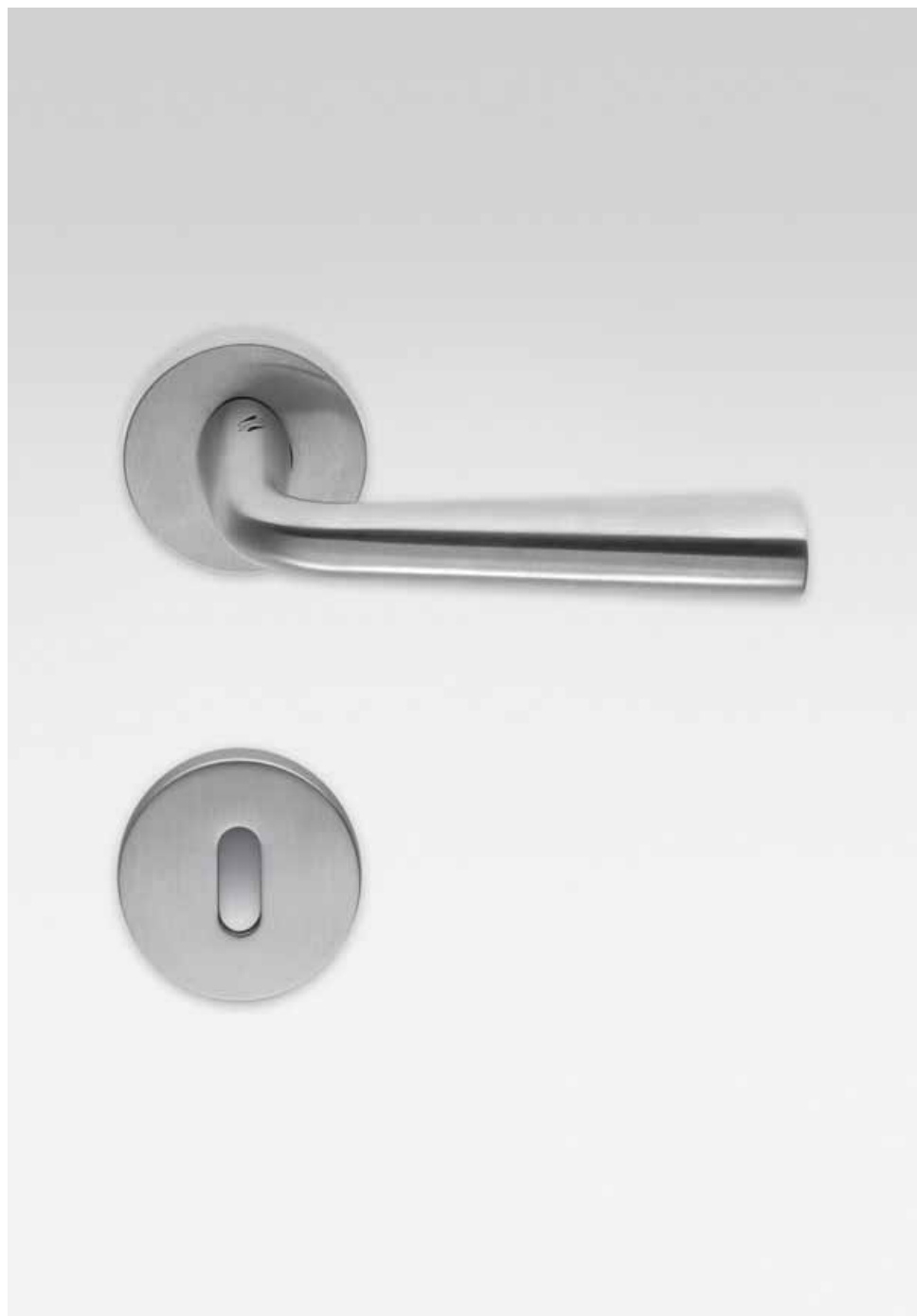

MD 11  
**TOOL** ○

Design: Michele De Lucchi



# tool

Design: Michele De Lucchi

Materiale: Ottone  
Material: Brass



**CR**  
Cromo  
Chrome



**CM**  
Cromat  
Matt chrome

VERSIONE STANDARD  
STANDARD VERSION

**MD 11 R-RY**

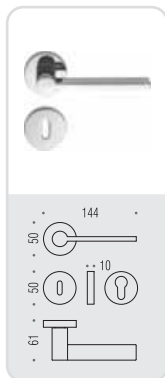

**CD 49 BZG G 6/8**



**MD 12 IM**

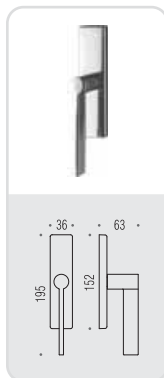

**MD 12 DK/SM**

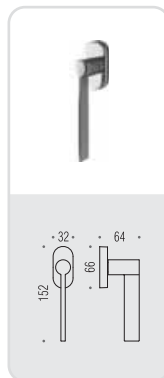

VARIANTI DISPONIBILI  
ALSO AVAILABLE

**MD 11 RF-RYF**

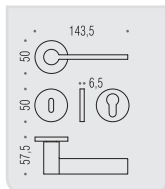

**FF 19 BZG 6/8**



**MD 12 DKF/SM**

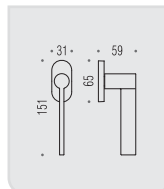

  
**six millimeters  
concept**  
maniglie con rosetta e bocchetta  
bassa che non necessitano di  
lavorazioni aggiuntive sulla porta.  
handles with slim rose and  
escutcheon don't need additional  
installation works on the door.



LC 71  
**TRAMA** ○

Design: Luca Colombo





# trama

Design: Luca Colombo

Materiale: Cromall®  
Material: Cromall®



six millimeters  
concept

maniglie con rosetta e bocchetta  
bassa che non necessitano di  
lavorazioni aggiuntive sulla porta,  
handles with slim rose and  
escutcheon don't need additional  
installation works on the door.



**CM/CR**  
Cromat/Cromo  
Matt chrome/Chrome

## LC 71 R-RY



## FF 19 BZG 6/8



## LC 72 IM

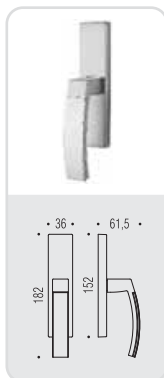

## LC 72 DK/SM

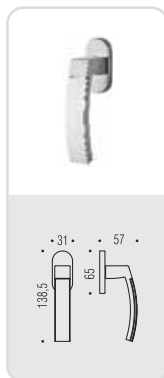



LC 81  
**TRAMA** ○

Design: Luca Colombo



# trama

Design: Luca Colombo

Materiale: Cromall®  
Material: Cromall®



six millimeters  
concept

maniglie con rosetta e bocchetta  
bassa che non necessitano di  
lavorazioni aggiuntive sulla porta.  
handles with slim rose and  
escutcheon don't need additional  
installation works on the door.



**CM/CR**  
Cromat/Cromo  
Matt chrome/Chrome

## LC 81 R-RY

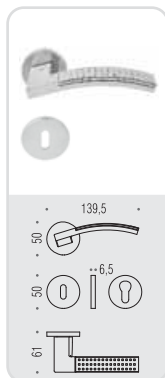

## FF 19 BZG 6/8



## LC 82 IM

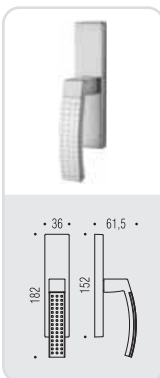

## LC 82 DK/SM

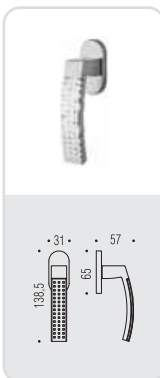



TK 11  
**TWITTY** ○  
Design: Tomo Kimura





# twitty

Design: Tomo Kimura

FREE STYLE  
COLLECTION

Materiale: Ottone  
Material: Brass



**OL**  
Oroplus



**CR**  
Cromo  
Chrome



**CM**  
Cromat  
Matt chrome

## TK 11 R-RY

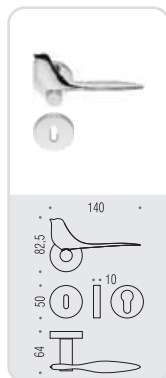

## CD 49 BZG G 6/8





AR 21  
**VIOLA** ○

Design: Angeletti Ruzza Design

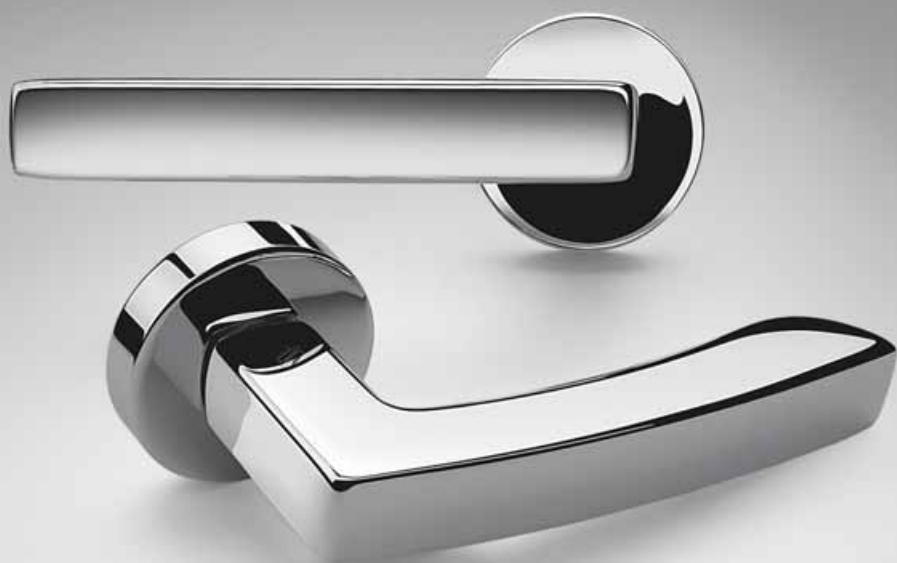

# viola

Design: Angeletti Ruzza Design

Materiale: Ottone  
Material: Brass



**OL**  
Oroplus



**CR**  
Cromo  
Chrome



**HPS/1**  
Zirconium stainless-steel HPS



**CM**  
Cromat  
Matt chrome



**VL**  
Vintage

*vintage*



**VM**  
Vintage Mat

*vintage*

## AR 21 R-RY

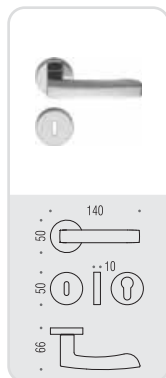

## CD 49 BZG G 6/8

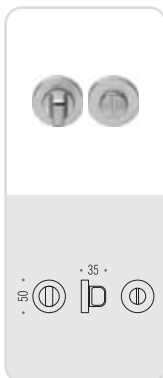

## AR 22 IM

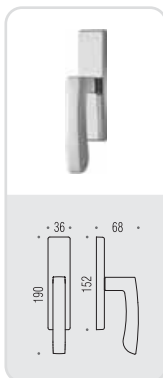

## AR 22 DK/SM

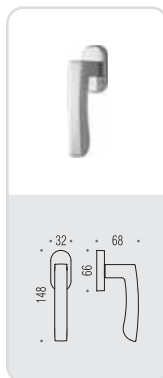



DB 31  
**WING** ○

Design: Ottavio Di Blasi





# wing

Design: Ottavio Di Blasi

Materiale: Ottone  
Material: Brass



**OL**  
Oroplus



**CM**  
Cromat  
Matt chrome

## DB 31 R-RY

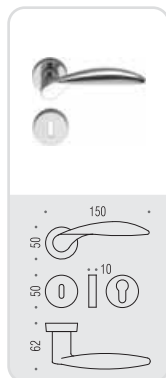

## CD 49 BZG G 6/8



## DB 32 IM

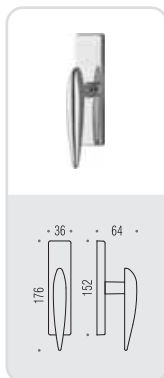

## DB 32 DK/SM

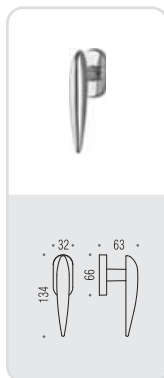



MM 11  
**ZELDA** 

Design: Jean Marie Massaud



# zelda

Design: Jean Marie Massaud

Materiale: Ottone  
Material: Brass



**CR**  
Cromo  
Chrome



**CM**  
Cromat  
Matt chrome

VERSIONE STANDARD  
STANDARD VERSION

**MM 11 R-RY**

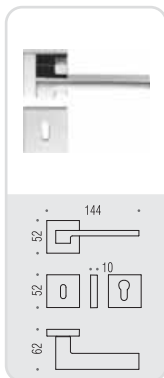

**MM 29 BZG 6/8**



**MM 12 IM**

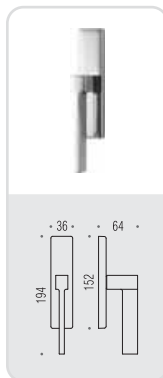

**MM 12 DK/SM**

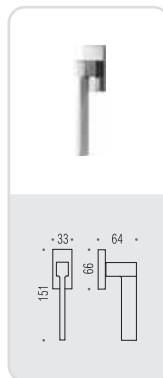

VARIANTI DISPONIBILI  
ALSO AVAILABLE

**MM 11 R-RYF**

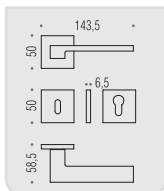

**FF 29 BZG 6/8**

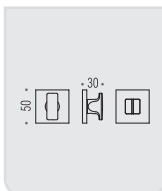

**MM 12 DKF/SM**

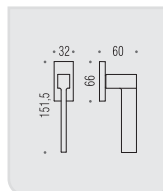

**six millimeters  
concept**

maniglie con rosetta e bocchetta  
bassa che non necessitano di  
lavorazioni aggiuntive sulla porta.  
handles with slim rose and  
escutcheon don't need additional  
installation works on the door.







*Classic Line*

**DB 41**  
**CAMEO** 

Design: Ottavio Di Blasi



# cameo

Design: Ottavio Di Blasi

Materiale: Ottone  
Material: Brass



**OL**  
Oroplus



**CR**  
Cromo  
Chrome



**BR**  
Bronzo  
Bronze

## DB 41 P-PY

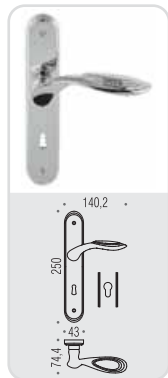

## DB 41 R-RY

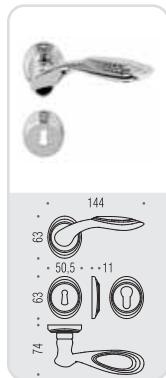

## DB 19 BZG 6/8



## DB 42 IM

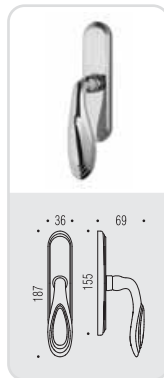

## DB 42 DK/SM

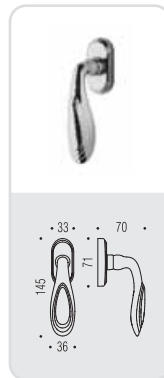



CD 31  
**HEIDI** ○

Design: Colombo Design



# heidi

Design: Colombo Design

Materiale: Ottone  
Material: Brass



**OL**  
Oroplus



**BR**  
Bronzo  
Bronze

## CD 31 P-PY

OL BR

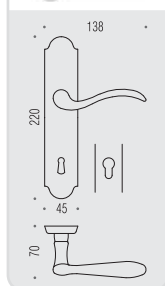

## CD 31 R-RY

OL BR

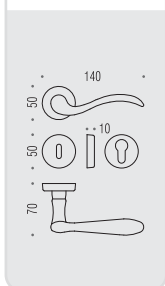

## CD 69 BZG G 6/8

OL BR

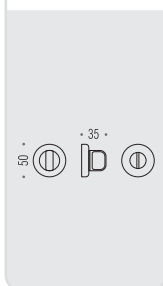

## CD 32 M

OL BR

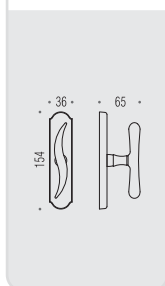

## CD 32 DK/SM DX-SX

OL BR

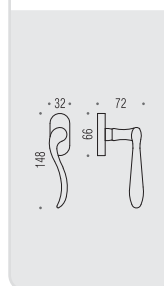
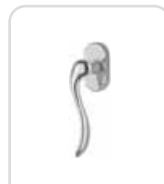





ID 31  
**IDA** ○  
Design: Colombo Design



# ida

Design: Colombo Design

Materiale: Ottone  
Material: Brass



**OL**  
Oroplus



**CR**  
Cromo  
Chrome



**BR**  
Bronzo  
Bronze



**OA**  
Ottone antico  
Antique brass



**BA**  
Bronzo antico  
Antique bronze

## ID 31 P-PY

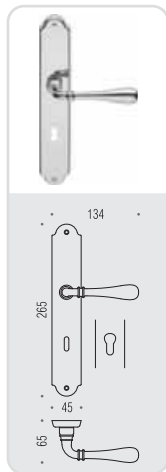

## ID 31 R-RY

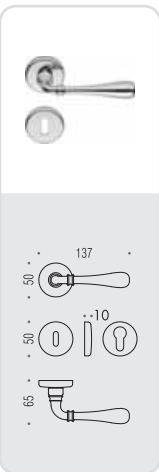

## CD 69 BZG G 6/8

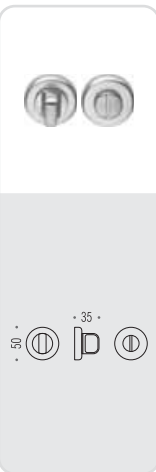

## ID 32 M



## ID 32 DK/SM

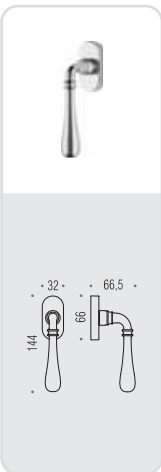



ID 11  
**PETER** ○

Design: Colombo Design



# peter

Design: Colombo Design

Materiale: Ottone  
Material: Brass



**OL**  
Oroplus



**OM**  
Oromat  
Matt gold



**BR**  
Bronzo  
Bronze



**OA**  
Ottone antico  
Antique brass

## ID 11 P-PY

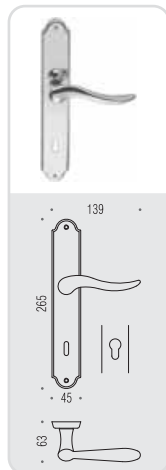

## ID 11 R-RY

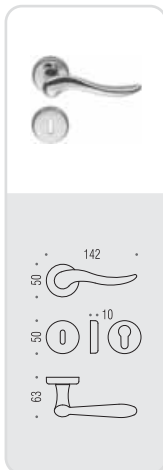

## CD 69 BZG G 6/8

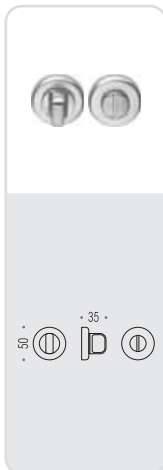

## CD 32 M

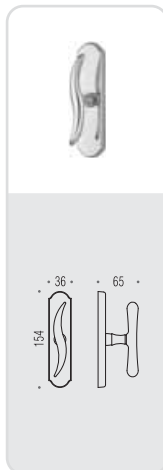

## ID 12 DK/SM DX-SX

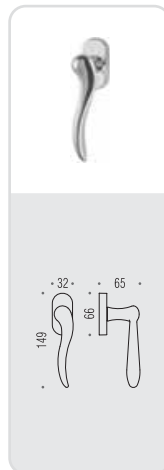





AR 11  
**PIUMA** ○

Design: Angeletti Ruzza Design



# piuma

Design: Angeletti Ruzza Design

Materiale: Ottone  
Material: Brass



**OL**  
Oroplus



**BR**  
Bronzo  
Bronze

## AR 11 P-PY

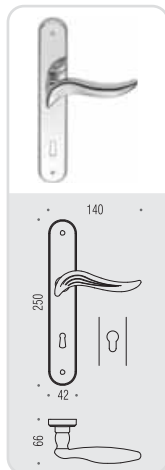

## AR 11 R-RY

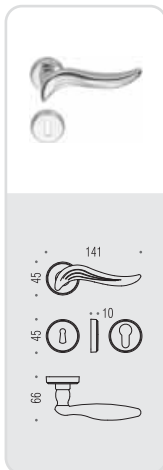

## CD 79 BZG 6/8

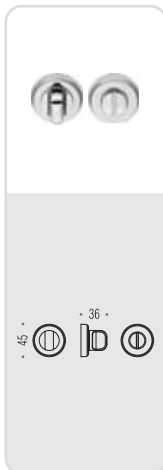

## AR 12 M

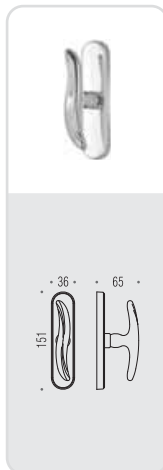

## AR 12 DK/SM

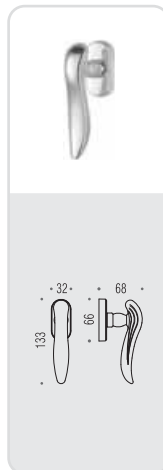





ROBOTECH®

CD 81  
**MACH**○

Design: Colombo Design





# mach

Design: Colombo Design



Materiale: Cromal®/Ottone  
Material: Cromal®, Brass



**HPS**  
Zirconium gold HPS



**CM**  
Cromat  
Matt chrome



**OL**  
Oroplus



**NI**  
Nikelmat  
Matt nickel



**OM**  
Oromat  
Matt gold



**OA**  
Ottone antico  
Antique brass

## CD 81 P-PY



## CD 81 R-RY



## CD 69 BZG G 6/8



## CD 82 IM



## CD 82 DK/SM

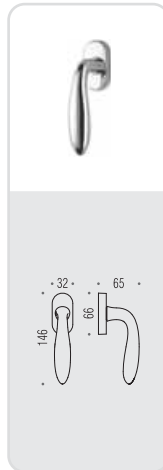
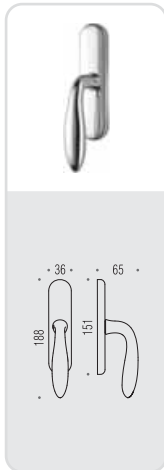
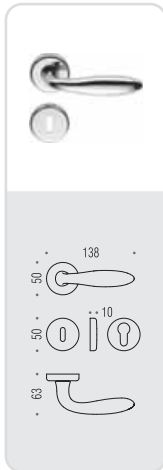
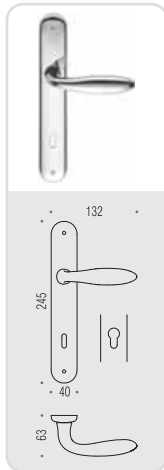



CD 41  
**ROBOT** ○

Design: Colombo Design



# robot

Design: Colombo Design



Materiale: Cromal®  
Material: Cromal®



**OL**  
Oroplus



**CR**  
Cromo  
Chrome



**NM**  
Neromat  
Matt black



**CM**  
Cromat  
Matt chrome



**BI**  
Bianco  
White

## CD 41 P-PY



## CD 41 R-RY



## CD 69 BZG 6/8



## CD 42 M



## CD 42 IM



## CD 42 DK/SM

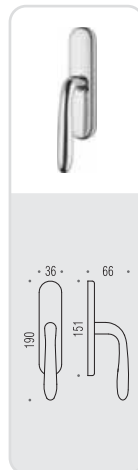
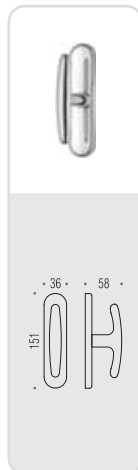
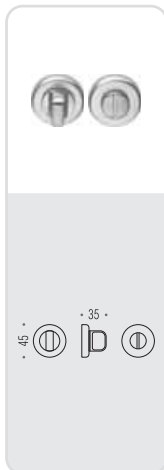
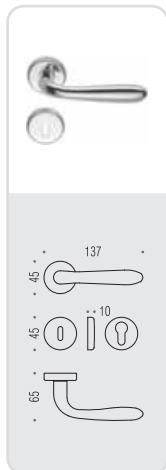
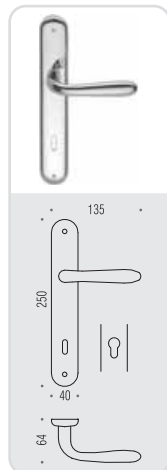



**CD 75**  
**ROBOT** ○

Design: Colombo Design





# robot

Design: Colombo Design



Materiale: Ottone  
Material: Brass



**HPS**  
Zirconium gold HPS



**OM**  
Cromat  
Matt gold



**CM**  
Cromat  
Matt chrome



**CR**  
Cromo  
Chrome



**BR**  
Bronzo  
Bronze

## CD 75 R-RY



## CD 69 BZG 6/8

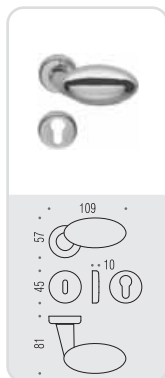



CD 51  
**ROBODUE** ○

Design: Colombo Design



# robodue

Design: Colombo Design



Materiale: Cromall®  
Material: Cromall®



**OL**  
Oroplus



**CR**  
Cromo  
Chrome



**CM**  
Cromat  
Matt chrome

## CD 51 P-PY

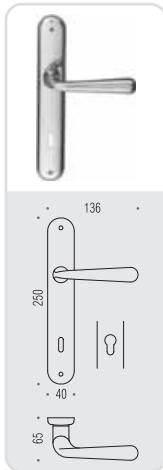

## CD 51 R-RY

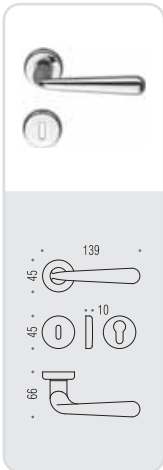

## CD 69 BZG 6/8

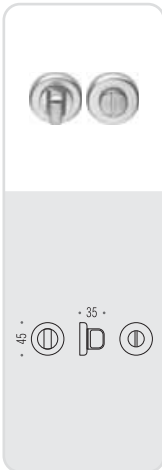

## CD 52 M

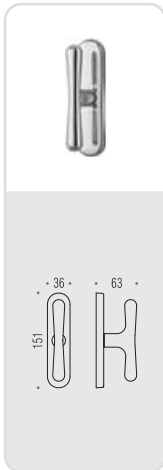

## CD 52 DK/SM

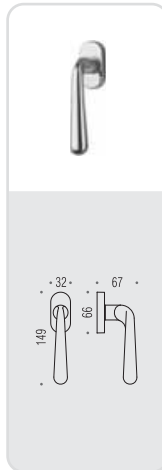



CD 91  
**ROBOTRE** ○

Design: Colombo Design





# robotre

Design: Colombo Design



Materiale: Cromal®/Ottone  
Material: Cromal®, Brass



**HPS**  
Zirconium gold HPS



**CR**  
Cromo  
Chrome



**OL**  
Oroplus



**CM**  
Cromat  
Matt chrome



**OM**  
Oromat  
Matt gold



**BR**  
Bronzo  
Bronze

## CD 91 P-PY



## CD 91 R-RY



## CD 69 BZG G 6/8



## CD 92 IM



## CD 92 DK/SM

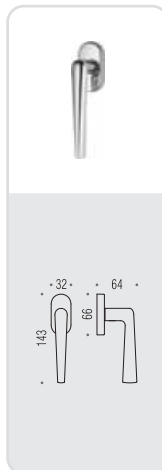
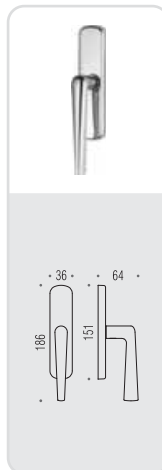
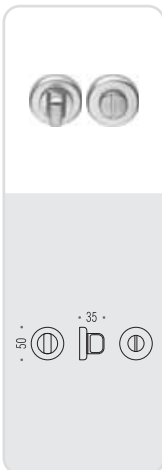
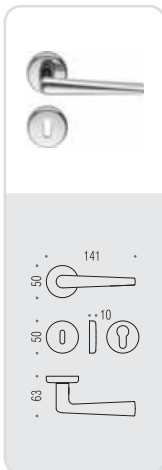
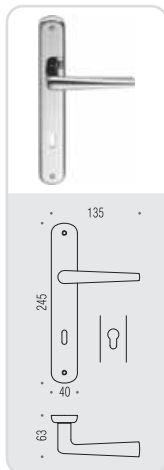



**ROBOQUATTRO** ID 41 

Design: Colombo Design



# roboquattro

Design: Colombo Design

Materiale: Cromall®

Material: Cromall®



**OL**  
Oroplus



**OM**  
Oromat  
Matt gold



**CR**  
Cromo  
Chrome



**CM**  
Cromat  
Matt chrome

## ID 41 R-RY

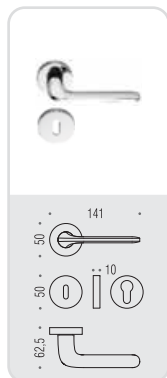

## CD 49 BZG G 6/8

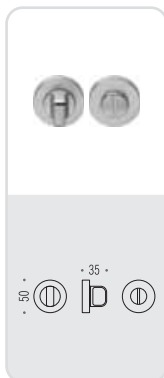

## ID 42 IM

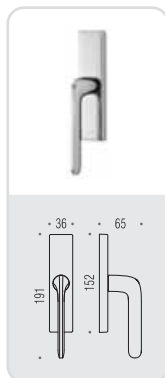

## ID 42 DK/SM

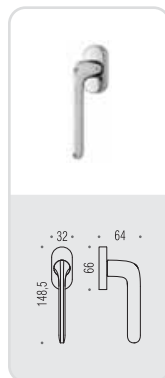



**ROBOQUATTRO** ID 51

Design: Colombo Design







# roboquattro<sub>S</sub>

Design: Colombo Design

Materiale: Cromall®

Material: Cromall®



**OL**  
Oroplus



**CR**  
Cromo  
Chrome



**CM**  
Cromat  
Matt chrome



**VL**  
Vintage

*vintage*



**VM**  
Vintage Mat

*vintage*

## ID 51 R-RY

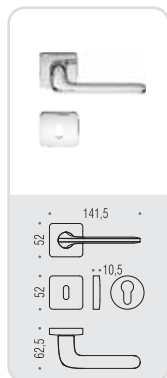

## PT 19 BZG 6/8

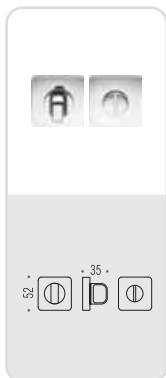

## ID 42 IM

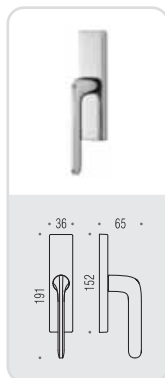

## ID 52 DK/SM

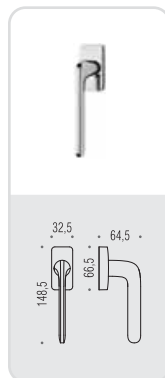





**POMOLI**  
DOOR KNOBS

# bold

Design: Pio e Tito Toso lab

Materiale: Ottone  
Material: Brass



## PT 15

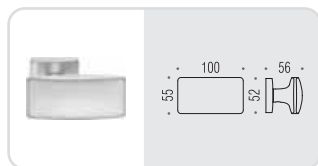

# cut

Design: Messineo e Settimelli

Materiale: Cromall®/Ottone  
Material: Cromall®/Brass



**CR**  
Cromo  
Chrome



**CM**  
Cromat  
Matt chrome

## MS 15

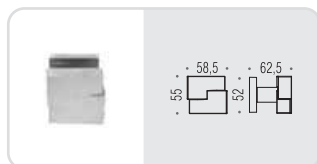

## MS 25

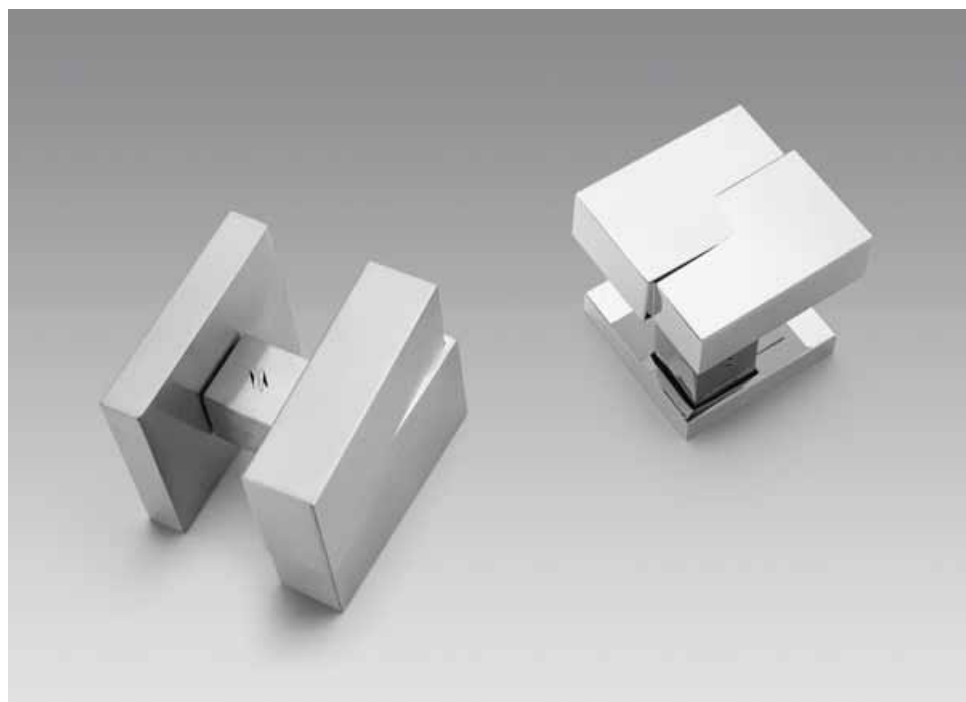
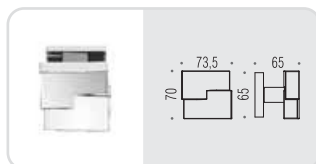

# daytona

Design: *pininfarina*

Materiale: Ottone  
Material: Brass



**HPS**  
Zirconium  
gold HPS



**CM**  
Cromat  
Matt chrome

## PF 15

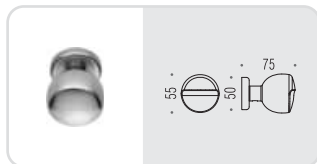



# drop

Design: Luca Colombo

Materiale: Ottone  
Material: Brass



**HPS**  
Zirconium  
gold HPS



**CR**  
Cromo  
Chrome



**CM**  
Cromat  
Matt chrome

**BR**  
Bronzo  
Bronze

## LC 45

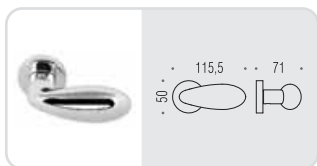

# etro

Design: Di Blasi Associati

Materiale: Ottone  
Material: Brass

**OL/OM**  
Oroplus/Oromat  
Oroplus/Matt gold



**CR/CM**  
Cromo/Cromat  
Chrome/Matt chrome

**DB 15**

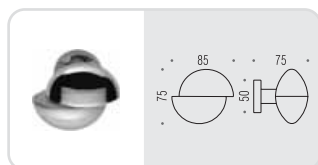

# moon

Design: Bartoli Design

Materiale: Ottone  
Material: Brass



**HPS**  
Zirconium  
gold HPS



**CR**  
Cromo  
Chrome



**CM**  
Cromat  
Matt chrome

## BD 15

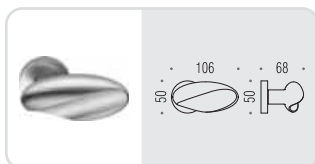

# push

Design: Luca Colombo

Materiale: Ottone

Material: Brass



**HPS**  
Zirconium  
gold HPS



**CR**  
Cromo  
Chrome



**CM**  
Cromat  
Matt chrome

## LC 55

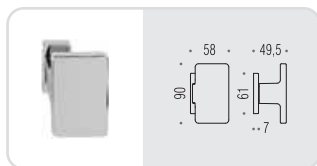

# robot

Design: Colombo Design



Materiale: Ottone  
Material: Brass



**HPS**  
Zirconium  
gold HPS



**OL**  
Oroplus

**OM**  
Oromat  
Matt gold



**HPS/1**  
Zirconium  
stainless-steel HPS



**CR**  
Cromo  
Chrome



**CM**  
Cromat  
Matt chrome

**NI**  
Nikelmat  
Matt nickel

**BR**  
Bronzo  
Bronze

**BA**  
Bronzo antico  
Antique bronze

**OA**  
Ottone antico  
Antique brass

## CD 45



## CD 55



## CD 65

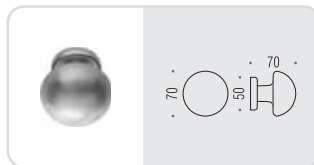

# robot

Design: Colombo Design



Materiale: Ottone

Material: Brass



**HPS**  
Zirconium  
gold HPS

**OM**  
Oromat  
Matt gold



**CR**  
Cromo  
Chrome



**CM**  
Cromat  
Matt chrome

**BR**  
Bronzo  
Bronze

## CD 75

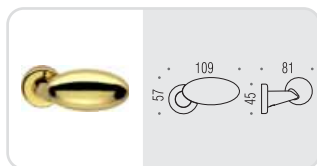

# round

Design: Colombo Design

Materiale: Ottone  
Material: Brass



**HPS**  
Zirconium  
gold HPS



**OL**  
Oroplus



**CR**  
Cromo  
Chrome



**CM**  
Cromat  
Matt chrome

## ID 25



## ID 35

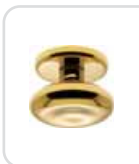

# spider

Design: Matteo Ragni

Materiale: Ottone  
Material: Brass



**CR**  
Cromo  
Chrome



**CM**  
Cromat  
Matt chrome

## MR 15

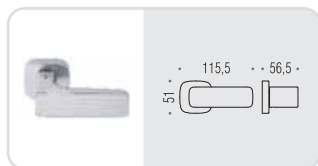



# square

Design: Luca Colombo

Materiale: Ottone  
Material: Brass



**CR**  
Cromo  
Chrome



**CM**  
Cromat  
Matt chrome



**VL**  
Vintage



**VM**  
Vintage Mat

## LC 15



## LC 25

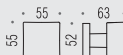

## LC 35

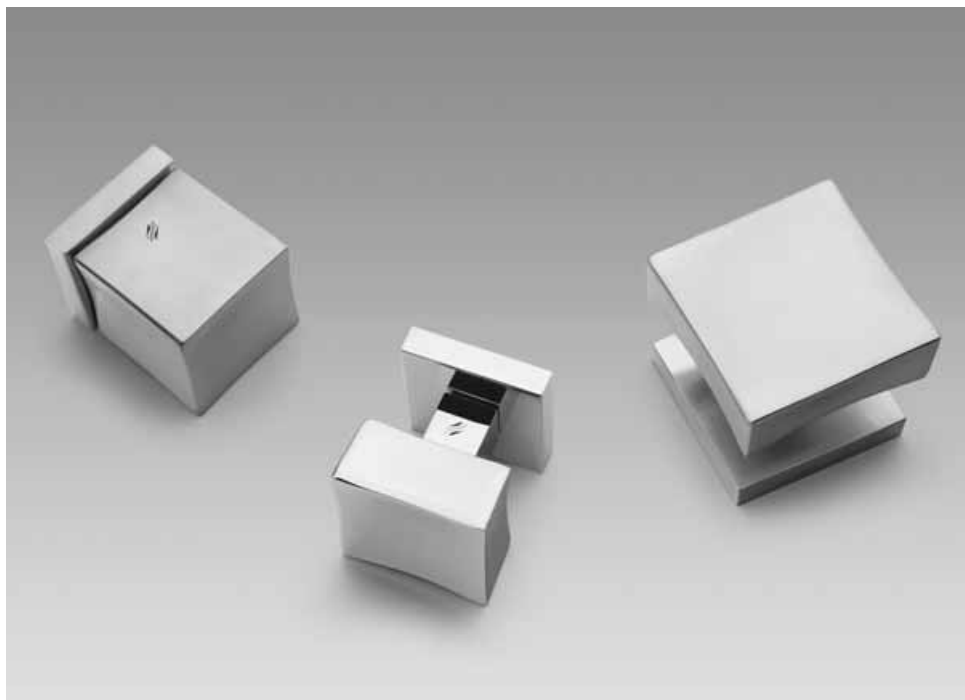
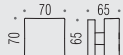



**MANIGLIONI  
E BATTENTI**  
P U L L S   A N D  
D O O R   K N O C K E R S

# daytona

Design: *pininfarina*

MANIGLIONI SENZA ROSETTE  
PULLS WITHOUT ROSES

Materiale: Ottone  
Material: Brass



**HPS**  
Zirconium  
gold HPS



**CM**  
Cromat  
Matt chrome

## PF 16

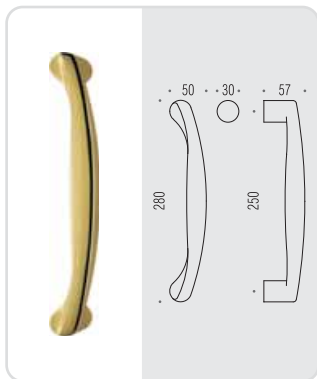

# elle

MANIGLIONI SENZA ROSETTE  
PULLS WITHOUT ROSES

Design: **TEAM 3**

Materiale: Cromal®  
Material: Cromal®



**HPS/1**  
Zirconium  
stainless-steel HPS



**OL**  
Oroplus



**CR**  
Cromo  
Chrome



**CM**  
Cromat  
Matt chrome

**ID 36**

**HPS1 OL CR CM VL VM**

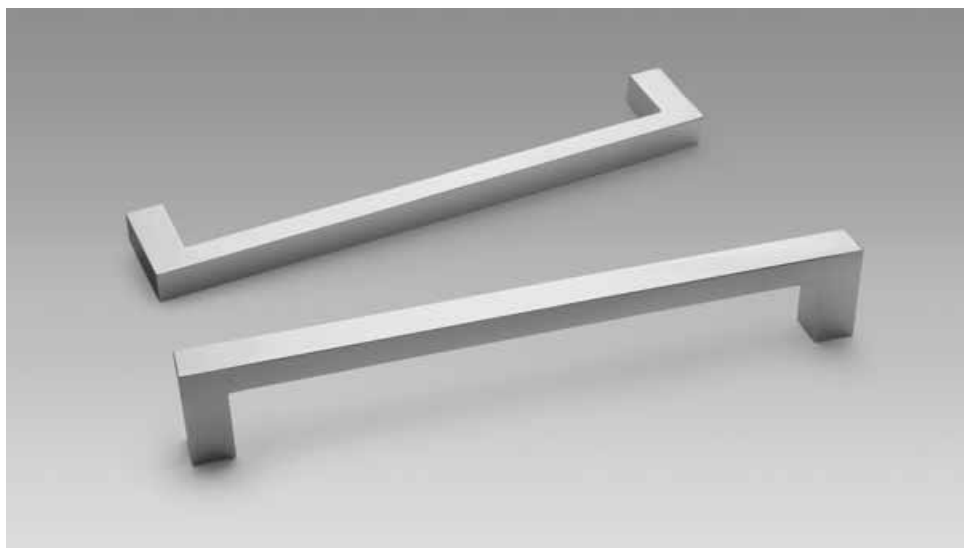
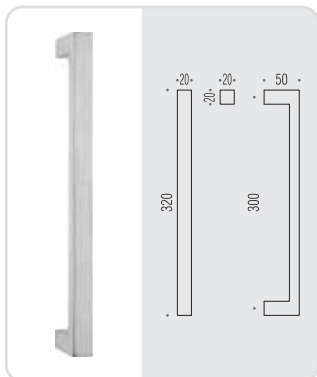

# estro

Design: Castiglia Associati

MANIGLIONI SENZA ROSETTE  
PULLS WITHOUT ROSES

Materiale: Ottone  
Material: Brass



**HPS**  
Zirconium  
gold HPS



**CM**  
Cromat  
Matt chrome

**CA 16 Z/A**

HPS CM

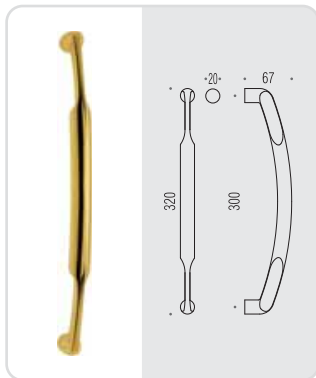

**CA 16 Z/B**

HPS CM

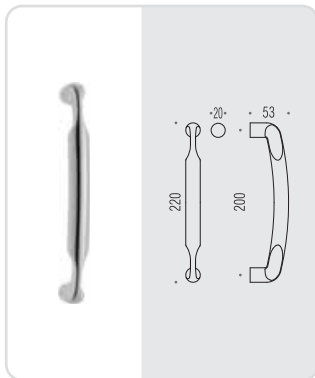

# estro

Design: Castiglia Associati

MANIGLIONI SENZA ROSETTE  
PULLS WITHOUT ROSES

Materiale: Ottone  
Material: Brass



**HPS**  
Zirconium  
gold HPS



**CM**  
Cromat  
Matt chrome

**CA 26 Z/A**

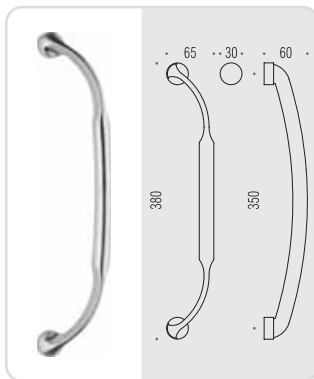

**CA 26 Z/B**

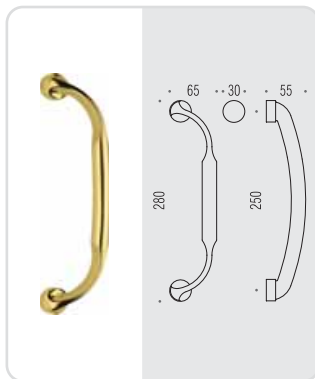

# flesso

Design: Carlo Bartoli

MANIGLIONI SENZA ROSETTE  
PULLS WITHOUT ROSES

Materiale: Ottone  
Material: Brass



**HPS**  
Zirconium  
gold HPS



**OL**  
Oroplus

**OM**  
Oromat  
Matt gold



**HPS/1**  
Zirconium  
stainless-steel HPS



**CR**  
Cromo  
Chrome



**CM**  
Cromat  
Matt chrome

**NM**  
Neromat  
Matt black

## CB 16 Z/A

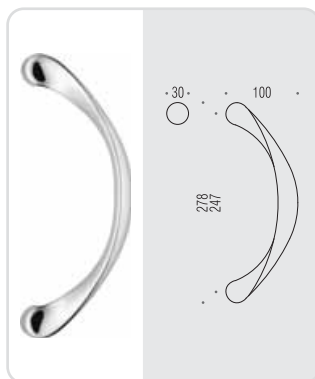

## CB 16 Z/B

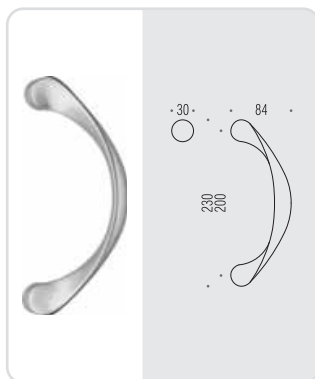



# logo

Design: Luca Colombo

MANIGLIONI SENZA ROSETTE  
PULLS WITHOUT ROSES

Materiale: Ottone  
Material: Brass



**HPS**  
Zirconium  
gold HPS



**OL**  
Oroplus



**CR**  
Cromo  
Chrome



**CM**  
Cromat  
Matt chrome

## LC 16

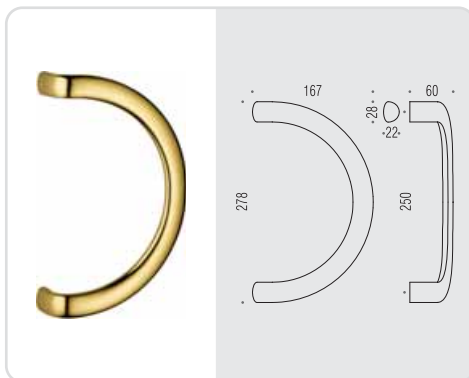

## LC 16 L

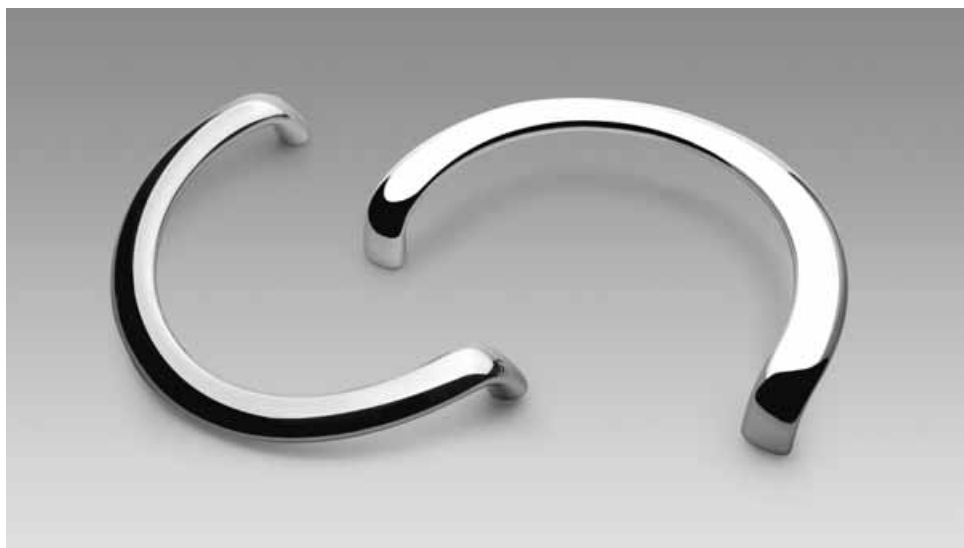
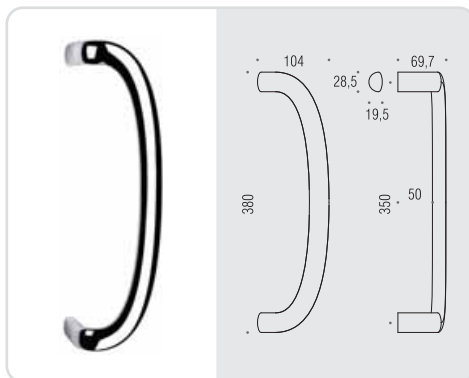

# lund

Design: Claesson Koivisto Rune

MANIGLIONI SENZA ROSETTE  
PULLS WITHOUT ROSES

Materiale: Ottone  
Material: Brass



**CR**  
Cromo  
Chrome



**CM**  
Cromat  
Matt chrome



**GL**  
Grafite  
Graphite



**GM**  
Grafite Mat  
Matt graphite

**SE 16**

CR CM GL GM

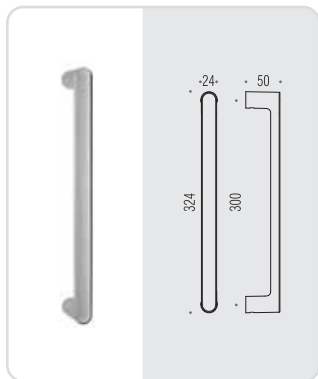

# noa

Design: **TEAM 3**

MANIGLIONI SENZA ROSETTE  
PULLS WITHOUT ROSES

Materiale: Ottone  
Material: Brass



## ID 16 A

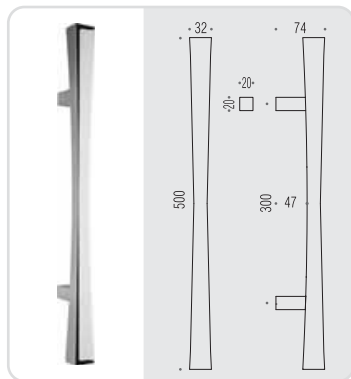

## ID 16 B

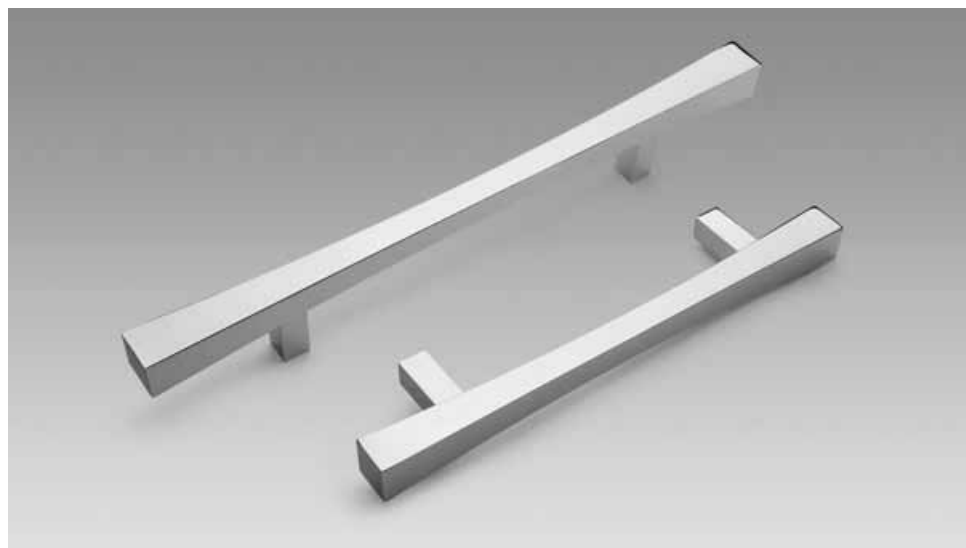
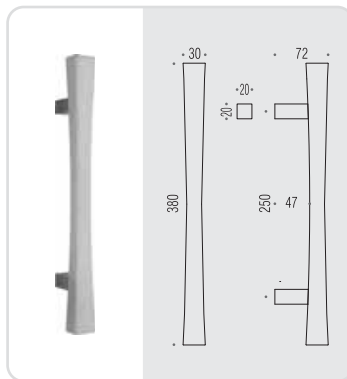

# noa

Design: **TEAM 3**

MANIGLIONI SENZA ROSETTE  
PULLS WITHOUT ROSES

Materiale: Ottone  
Material: Brass



**HPS**  
Zirconium  
gold HPS



**HPS/1**  
Zirconium  
stainless-steel HPS



**CR**  
Cromo  
Chrome



**CM**  
Cromat  
Matt chrome

## ID 26 A

HPS HPS1 CR CM

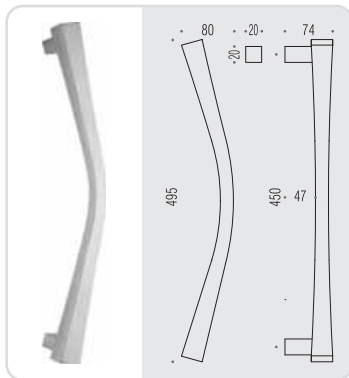

## ID 26 B

HPS HPS1 CR CM

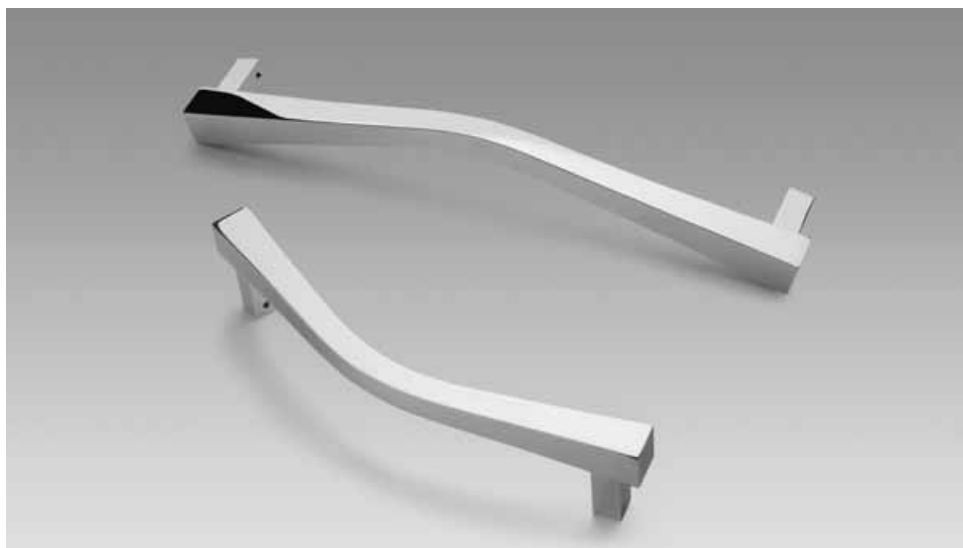
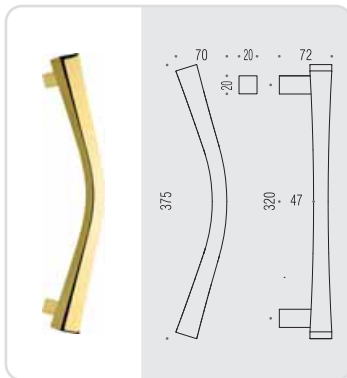

# roboquattro

Design: Colombo Design

MANIGLIONI SENZA ROSETTE  
PULLS WITHOUT ROSES

Materiale: Ottone  
Material: Brass



**HPS**  
Zirconium  
gold HPS



**OL**  
Oroplus

**OM**  
Oromat  
Matt gold



**CR**  
Cromo  
Chrome



**CM**  
Cromat  
Matt chrome

## ID 46 A

HPS OL OM CR CM

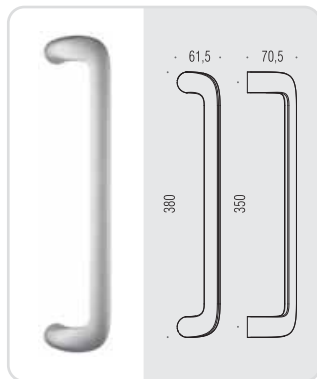

## ID 46 B

HPS OL OM CR CM

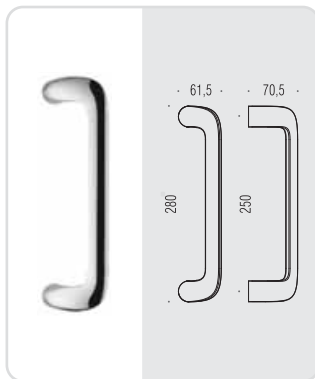

# square

Design: Architettura Laboratorio

MANIGLIONI SENZA ROSETTE  
PULLS WITHOUT ROSES

Materiale: Ottone  
Material: Brass



## MG 26

HPS HPS1 CM VL VM

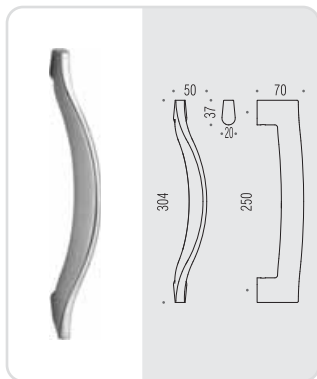

# tender

Design: Architettura Laboratorio

MANIGLIONI SENZA ROSETTE  
PULLS WITHOUT ROSES

Materiale: Ottone  
Material: Brass



**HPS**  
Zirconium  
gold HPS



**OL**  
Oroplus

**OM**  
Oromat  
Matt gold



**CR**  
Cromo  
Chrome



**CM**  
Cromat  
Matt chrome

**NI**  
Nikelmat  
Matt nickel

**BA**  
Bronzo antico  
Antique bronze

**OA**  
Ottone antico  
Antique brass

**NM**  
Neromat  
Matt black

## MG 16

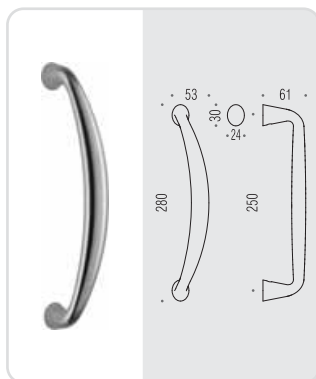

## MG 16 L

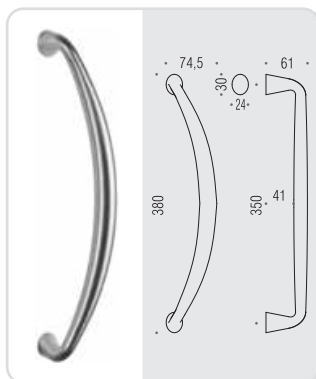

# wave

Design: Marco Piva

MANIGLIONI SENZA ROSETTE  
PULLS WITHOUT ROSES

Materiale: Ottone  
Material: Brass



**HPS/1**  
Zirconium  
stainless-steel HPS



**CM**  
Cromat  
Matt chrome

## MP 16 A

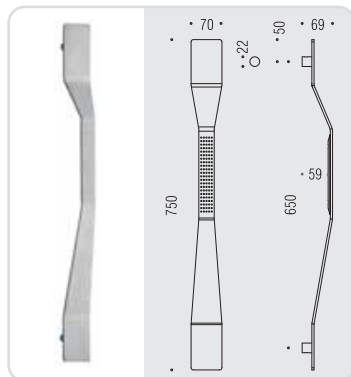

## MP 16 B

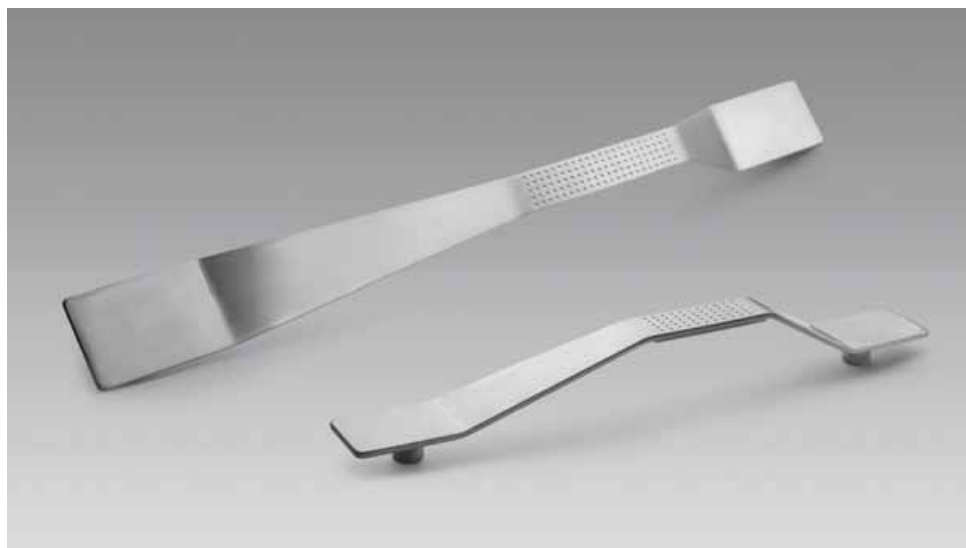
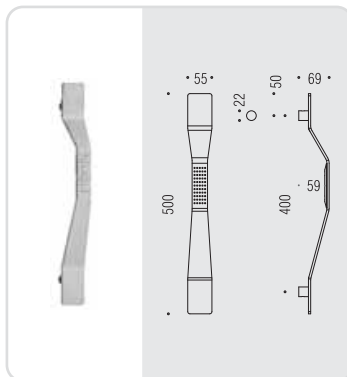



# zen

Design: Bartoli Design

MANIGLIONI SENZA ROSETTE  
PULLS WITHOUT ROSES

Materiale: Ottone  
Material: Brass



## CB 36 A

HPS HPS1 CR CM

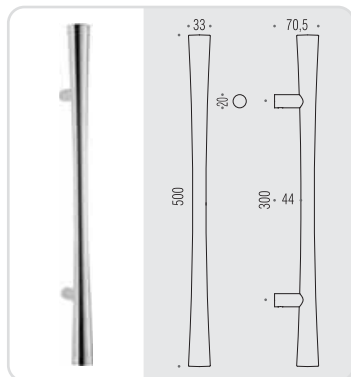

## CB 36 B

HPS HPS1 CR CM

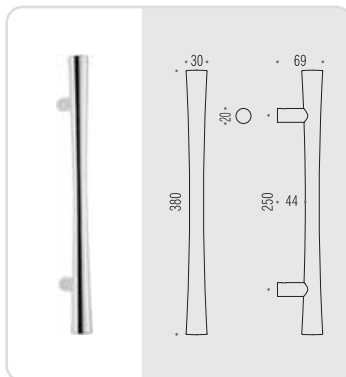

# zen

Design: Bartoli Design

MANIGLIONI SENZA ROSETTE  
PULLS WITHOUT ROSES

Materiale: Ottone  
Material: Brass



## CB 46 A

HPS HPS1 CR CM

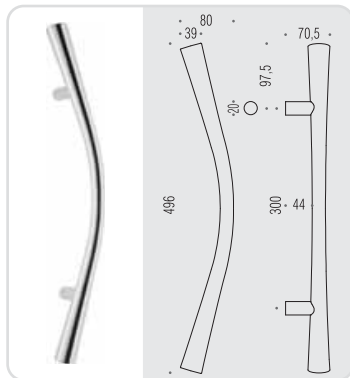

## CB 46 B

HPS HPS1 CR CM

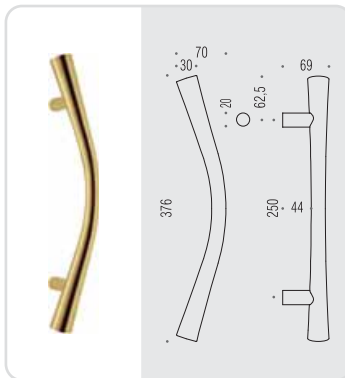

# blues

Design: Colombo Design

MANIGLIONI SENZA ROSETTE  
PULLS WITHOUT ROSES

Materiale: Ottone  
Material: Brass



**OL**  
Oroplus



**CR**  
Cromo  
Chrome



**CM**  
Cromat  
Matt chrome

## CD 36

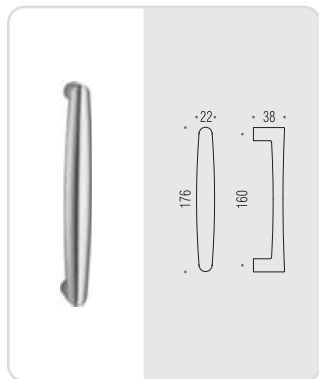

# jazz

Design: Bartoli Design

MANIGLIONI SENZA ROSETTE  
PULLS WITHOUT ROSES

Materiale: Ottone  
Material: Brass



**CD 26**

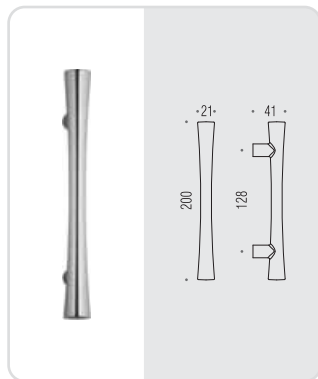

# nice

Design: Carlo Bartoli

MANIGLIONI CON ROSETTE  
PULLS WITH ROSETTES

Materiale: Ottone  
Material: Brass



**HPS**  
Zirconium  
gold HPS



**OL**  
Oroplus



**CM/CR**  
Cromat/Cromo  
Matt chrome/Chrome

**CB 26**

HPS OL CM CR

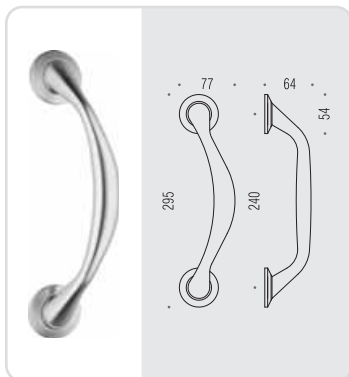

# piuma

Design: Angeletti Ruzza Design

MANIGLIONI CON ROSETTE  
PULLS WITH ROSES

Materiale: Ottone  
Material: Brass



**OL**  
Oroplus

**BR**  
Bronzo  
Bronze

**AR 16**

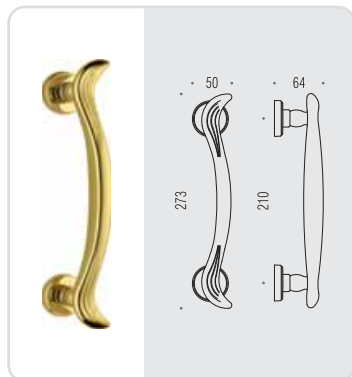

# robot

Design: Colombo Design

MANIGLIONI CON ROSETTE  
PULLS WITH ROSES

Materiale: Ottone  
Material: Brass



## CD 16 A

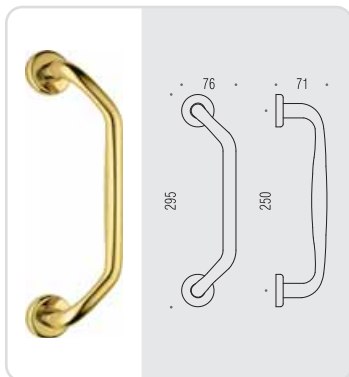

## CD 16 B

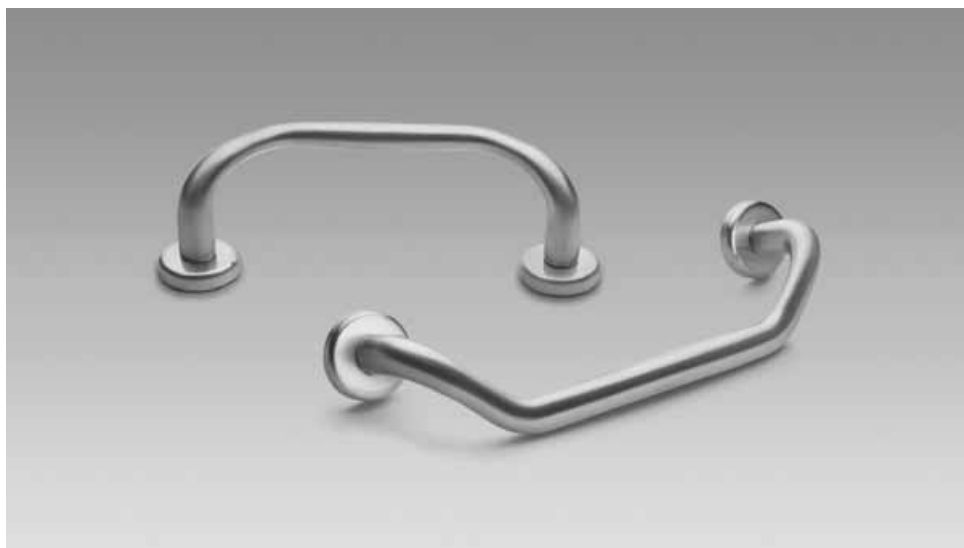
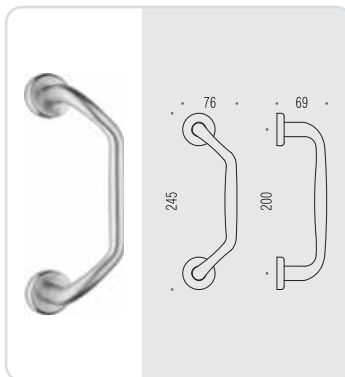

# cloud

Design: Luca Colombo

MANIGLIONI PER ANTE IN VETRO  
PULLS FOR GLASS DOOR

Materiale: Ottone  
Material: Brass



**HPS/1**  
Zirconium  
stainless-steel HPS



**CR**  
Cromo  
Chrome



**CM**  
Cromat  
Matt chrome

## LC 26

HPS1 CR CM

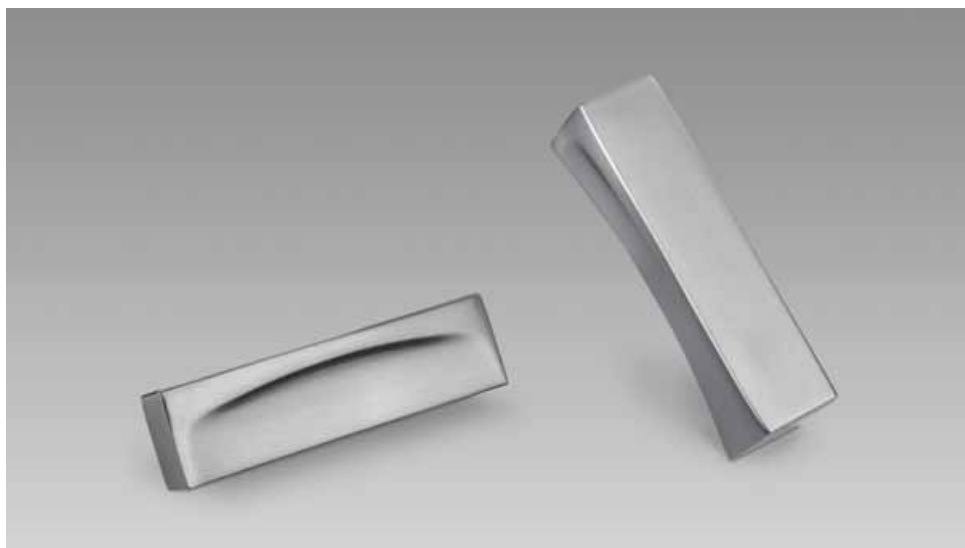
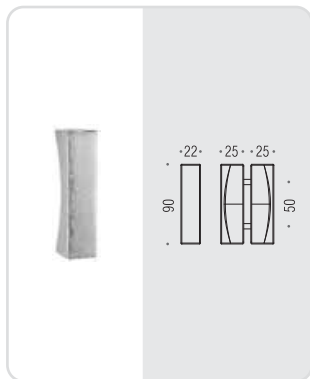



# wind

Design: Luca Colombo

MANIGLIONI PER ANTE IN VETRO  
PULLS FOR GLASS DOOR

Materiale: Ottone  
Material: Brass



**CR**  
Cromo  
Chrome



**CM**  
Cromat  
Matt chrome

**LC 36**

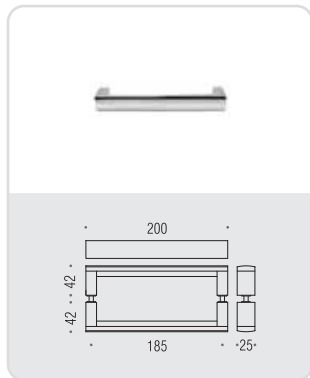

**LC 46**

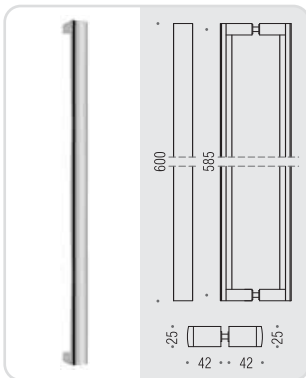

**LC 56**

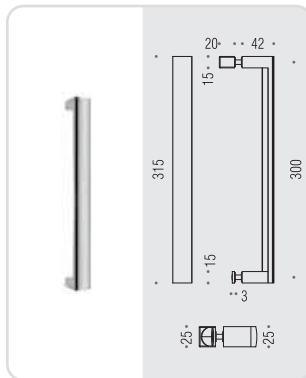

# am113/213y

Design: Alberto Meda

MANIGLIONI PER ALZANTE SCORREVOLE  
PULL-UP HANDLES FOR SLIDING DOOR

Materiale: Ottone  
Material: Brass



**HPS**  
Zirconium  
gold HPS



**OL**  
Oroplus

**OM**  
Oromat  
Matt gold



**CR**  
Cromo  
Chrome



**CM**  
Cromat  
Matt chrome

## AM 113

HPS OL OM CR CM

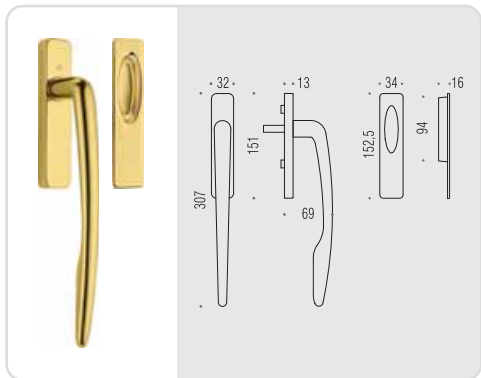

## AM 213 Y

OL CM

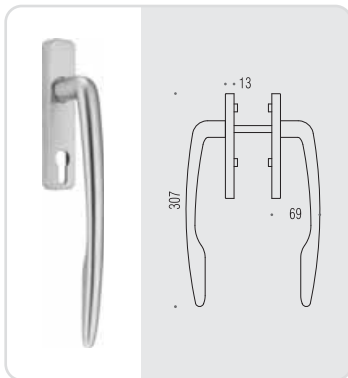

# id113/213y

Design: Colombo Design

MANIGLIONI PER ALZANTE SCORREVOLE  
PULL-UP HANDLES FOR SLIDING DOOR

Materiale: Ottone  
Material: Brass



**HPS**  
Zirconium  
gold HPS



**OL**  
Oroplus

**OM**  
Oromat  
Matt gold



**CR**  
Cromo  
Chrome



**CM**  
Cromat  
Matt chrome

**NI**  
Nikelmat  
Matt nickel

**BR**  
Bronzo  
Bronze

## ID 113

HPS OL OM CR CM NI BR

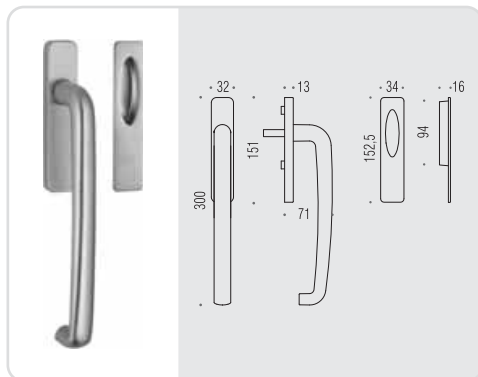

## ID 213 Y

HPS OL OM CR CM NI BR

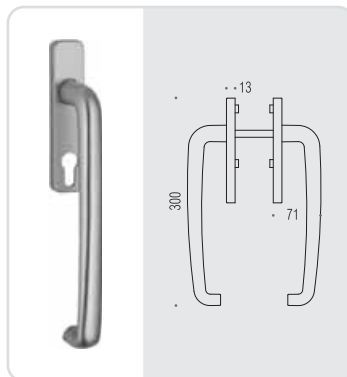

# id313/413y

Design: Colombo Design

MANIGLIONI PER ALZANTE SCORREVOLE  
PULL-UP HANDLES FOR SLIDING DOOR

Materiale: Ottone  
Material: Brass



**HPS**  
Zirconium  
gold HPS



**OL**  
Oroplus

**OM**  
Oromat  
Matt gold



**CR**  
Cromo  
Chrome



**CM**  
Cromat  
Matt chrome

## ID 313

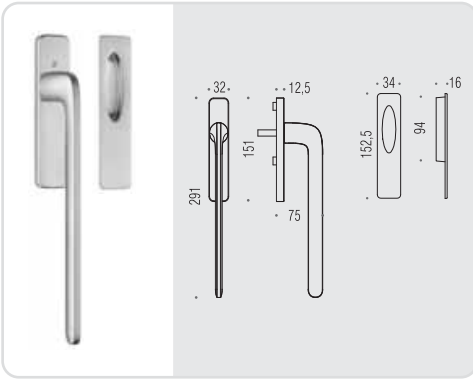

## ID 413 Y

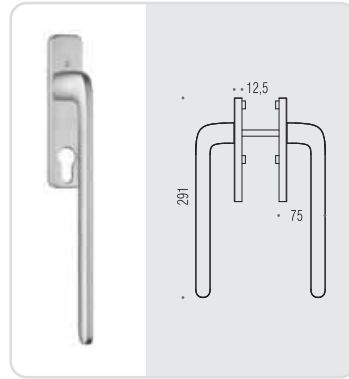

# lc113/213y

Design: Luca Colombo

MANIGLIONI PER ALZANTE SCORREVOLE  
PULL-UP HANDLES FOR SLIDING DOOR

Materiale: Ottone  
Material: Brass



**CR**  
Cromo  
Chrome



**CM**  
Cromat  
Matt chrome

## LC 113

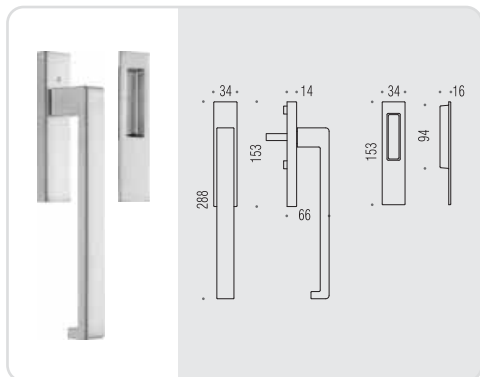

## LC 213 Y

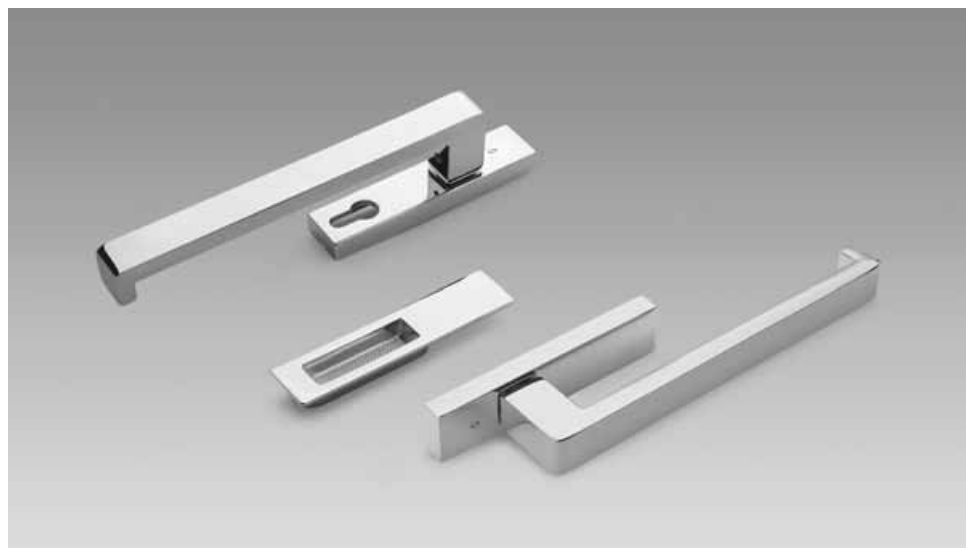
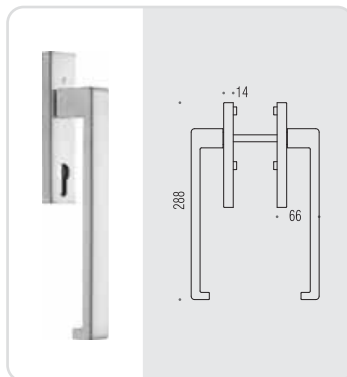

# lc413 / 513y

Design: Luca Colombo

MANIGLIONI PER ALZANTE SCORREVOLE  
PULL-UP HANDLES FOR SLIDING DOOR

Materiale: Ottone  
Material: Brass



**CR/CM**  
Cromo/Cromat  
Chrome/Matt chrome



**GL/GM**  
Grafito/Grafito Mat  
Graphite/Matt graphite

## LC 413

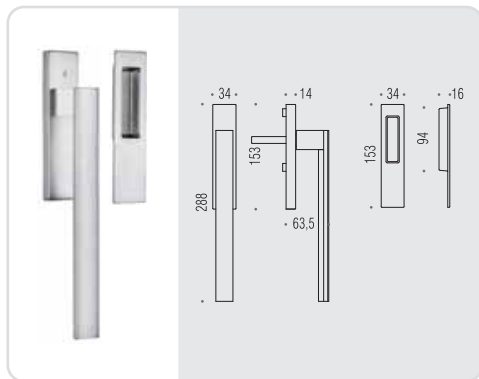

## LC 513 Y

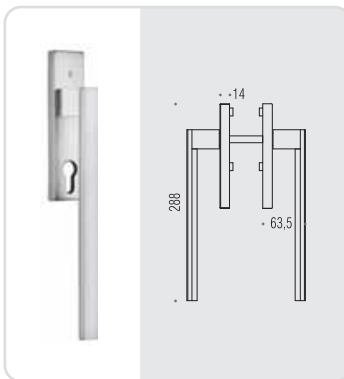

# cd113 mignon

Design: Colombo Design

MANIGLIONI PER ALZANTE SCORREVOLE  
PULL-UP HANDLES FOR SLIDING DOOR

Materiale: Ottone  
Material: Brass



## CD 113

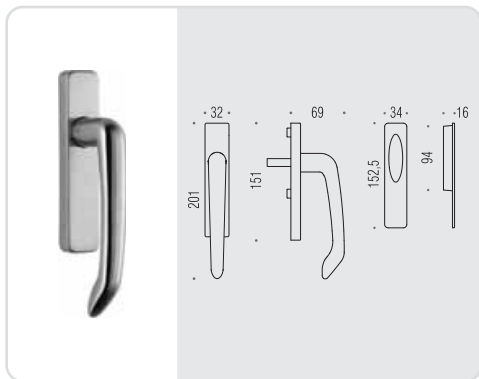

# cd213 rs

Design: Colombo Design

MANIGLIONI PER COMPLANARE  
PULL FOR COPLANAR SLIDING DOOR

Materiale: Ottone  
Material: Brass



## CD 213 RS

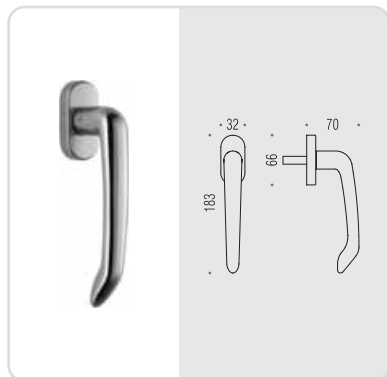



# flessum & toc-toc

Design: Bartoli Design

Design: Alberto Meda

BATTENTI  
DOOR KNOCKERS

Materiale: Ottone  
Material: Brass



**HPS**  
Zirconium  
gold HPS



**CM**  
Cromat  
Matt chrome

**BR**  
Bronzo  
Bronze

**BA**  
Bronzo antico  
Antique bronze

**OA**  
Ottone antico  
Antique brass

## CB 115 (FLESSUM)

HPS CM BR BA OA

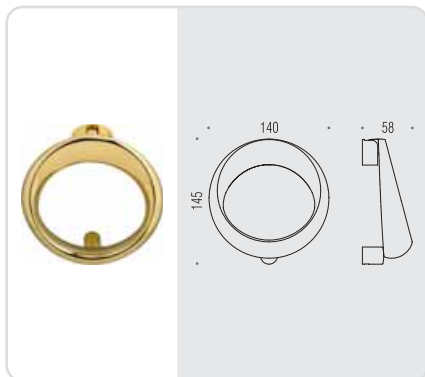

## AM 115 (TOC-TOC)

HPS CM

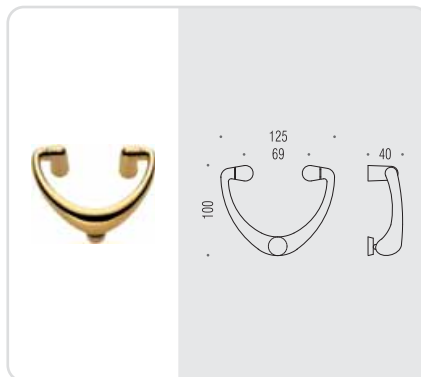



**MANIGLIE  
AD INCASSO**  
FLUSH HANDLES

# slide

Design: Bartoli Design

Materiale: Cromall® e ABS

Material: Cromall® and ABS



**CR**  
Cromo  
Chrome



**CM/CR**  
Cromat/Cromo  
Matt chrome/Chrome

## CB 2011

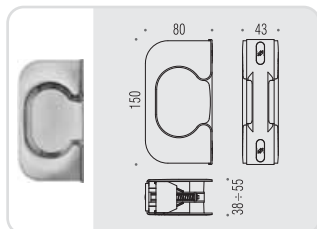

 Maniglia per porta scorrevole senza chiusura, utilizzabile su porte scorrevoli singole e doppie.  
Handle for sliding door without lock, to be used on single or double sliding doors.



## CB 2011 LK

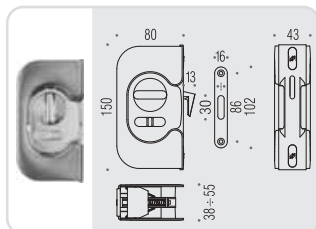

 Maniglia con possibilità di bloccaggio, utilizzabile su porte scorrevoli singole ed in abbinamento al modello CB2011 X anche su porte a doppio battente scorrevole.



 Handle for sliding door with sickle lock and tumb-turn lock, to be used on single sliding doors or combined with item n. CB2011 X also on double sliding leaf doors.

## CB 2011 X

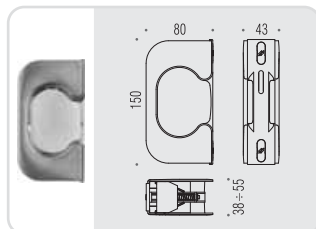

 Maniglia per porta scorrevole a doppio battente con foro ricezione gancio. Utilizzabile in abbinamento al modello CB2011 LK.

 Handle for double sliding leaf door with hole to insert the sickle lock. To be used in combination with item n. CB2011LK.



# enter

Design: Luca Colombo

SPESSORE PORTA da 40 a 52mm  
DOOR THICKNESS from 40 to 52mm

Materiale: Ottone  
Material: Brass



**OL**  
Oroplus

**OM**  
Oromat  
Matt gold



**CR**  
Cromo  
Chrome



**CM**  
Cromat  
Matt chrome

**NI**  
Nikelmat  
Matt nickel

## LC 211

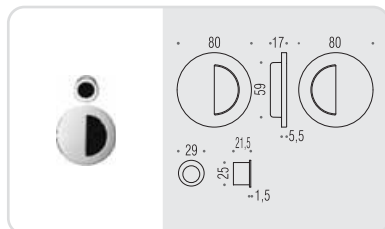

## LC 211 LK

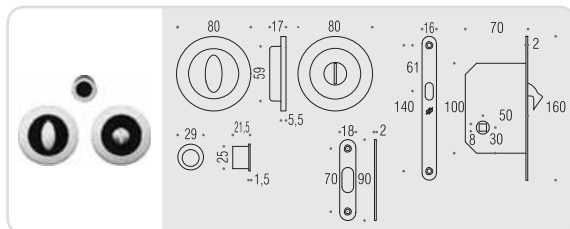

Kit per porta scorrevole composto da due maniglie ad incasso e maniglia di trascinamento.  
Sliding Doors Kit composed of two groove handles and flush handle.

Kit per porta scorrevole composto da due maniglie ad incasso con dispositivo di chiusura a nottolino, maniglia di trascinamento e serratura (E 50mm) a gancio dotata di contropiastro in acciaio inox.  
Sliding Doors Kit composed of two groove handles with thumb turn from one side, flush handle and stainless-steel mortise hook lock (E 50mm) with striking plate.

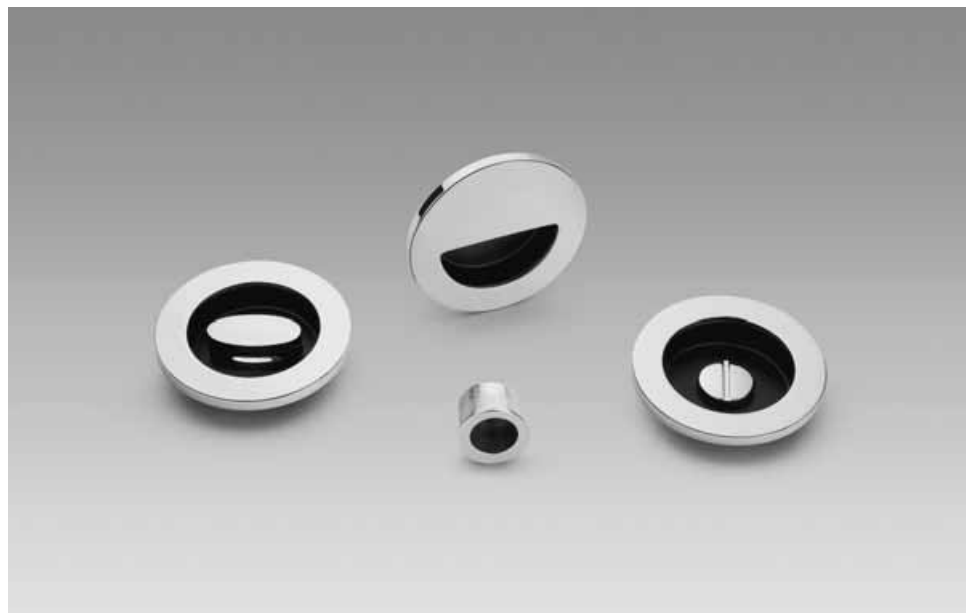

# open

Design: **TEAM 3**

SPESORE PORTA da 40 a 52mm  
DOOR THICKNESS from 40 to 52mm

Materiale: Ottone  
Material: Brass



**HPS**  
Zirconium  
gold HPS

**OM**  
Oromat  
Matt gold



**CR**  
Cromo  
Chrome



**CM**  
Cromat  
Matt chrome



**VL**  
Vintage



**VM**  
Vintage Mat

**NI**  
Nikelmat  
Matt nickel

**BR**  
Bronzo  
Bronze

## ID 211

HPS OM CR CM VL VM NI BR

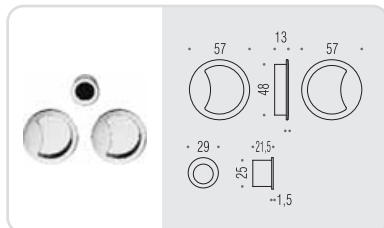

## ID 211 LK

HPS OM CR CM NI BR

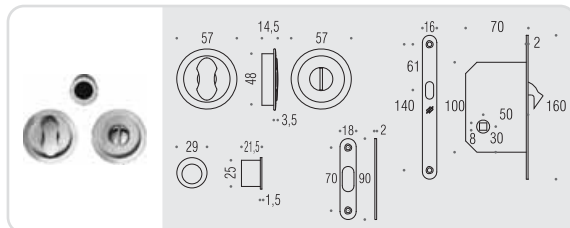

Kit per porta scorrevole composto da due maniglie ad incasso e maniglia di trascimento.  
Sliding Doors Kit composed of two groove handles and flush handle.

Kit per porta scorrevole composto da due maniglie ad incasso con dispositivo di chiusura a nottolino, maniglia di trascimento e serratura (E 50mm) a gancio dotata di controplastra in acciaio inox.  
Sliding Doors Kit composed of two groove handles with thumb turn from one side, flush handle and stainless-steel mortise hook lock (E 50mm) with striking plate.



# open

Design: **TEAM 3**

SPESSORE PORTA da 40 a 52mm  
DOOR THICKNESS from 40 to 52mm

Materiale: Ottone  
Material: Brass



**HPS**  
Zirconium  
gold HPS

**OM**  
Oromat  
Matt gold



**CR**  
Cromo  
Chrome



**CM**  
Cromat  
Matt chrome



**VL**  
Vintage  
Vintage



**VM**  
Vintage Mat  
Vintage Mat

**NI**  
Nikelmat  
Matt nickel

**BR**  
Bronzo  
Bronze

## ID 211 BZG

HPS OM CR CM VL VM NI BR

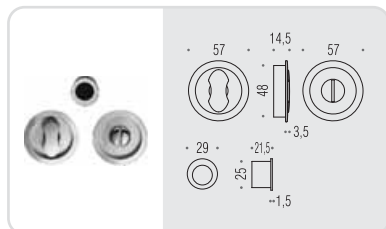

Kit per porta scorrevole composto da due maniglie ad incasso con dispositivo di chiusura a nottolino e maniglia di trascinamento (senza serratura).

Sliding Doors Kit composed of two groove handles with thumb turn and flush handle (without lock).



# open

Design: **TEAM 3**

SPESORE PORTA da 40 a 52mm  
DOOR THICKNESS from 40 to 52mm

Materiale: Ottone  
Material: Brass



**HPS**  
Zirconium  
gold HPS



**CR**  
Cromo  
Chrome



**CM**  
Cromat  
Matt chrome

**BR**  
Bronzo  
Bronze

## ID 211 LK WK

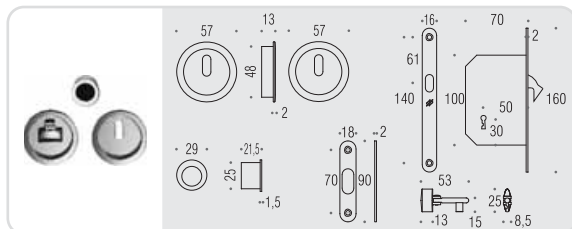

Kit per porta scorrevole composto da due maniglie ad incasso con dispositivo di chiusura con chiave, maniglia di trascinamento e serratura (E 50mm) a gancio dotata di contropiastra in acciaio inox.  
Sliding Doors Kit composed of two groove handles with key, flush handle and stainless-steel mortise hook lock (E 50mm) with striking plate.





Materiale: Ottone  
Material: Brass



**CR**  
Cromo  
Chrome



**CM**  
Cromat  
Matt chrome



**VL**  
Vintage



**VM**  
Vintage Mat

## ID 311

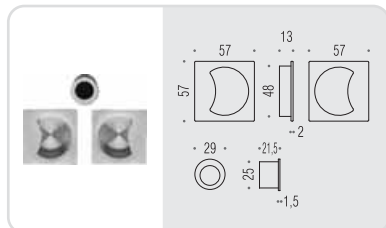

## ID 311 LK

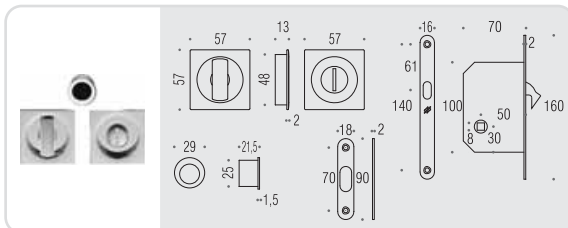

Kit per porta scorrevole composto da due maniglie ad incasso e maniglia di trascinamento.  
Sliding Doors Kit composed of two groove handles and flush handle.

Kit per porta scorrevole composto da due maniglie ad incasso con dispositivo di chiusura a nottolino, maniglia di trascinamento e serratura (E 50mm) a gancio dotata di contropiastre in acciaio inox.  
Sliding Doors Kit composed of two groove handles with thumb turn from one side, flush handle and stainless-steel mortise hook lock (E 50mm) with striking plate.



Materiale: Ottone  
Material: Brass



## ID 311 BZG

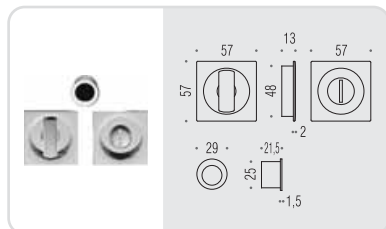

Kit per porta scorrevole composto da due maniglie ad incasso con dispositivo di chiusura a nottolino e maniglia di trascinamento (senza serratura).

Sliding Doors Kit composed of two groove handles with thumb turn and flush handle (without lock).



# cd111 - cd211

Design: Colombo Design

MISURA FRESATA 25 x 90 x 8mm  
MILING SIZE 25 x 90 x 8mm

Materiale: Ottone  
Material: Brass



**HPS**  
Zirconium  
gold HPS



**OL**  
Oroplus

**OM**  
Oromat  
Matt gold



**CR**  
Cromo  
Chrome



**CM**  
Cromat  
Matt chrome

**BR**  
Bronzo  
Bronze

## CD 111

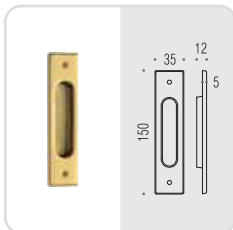

## CD 111 CF

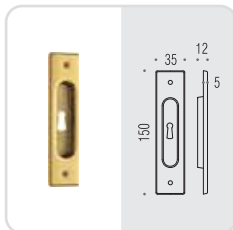

## CD 211

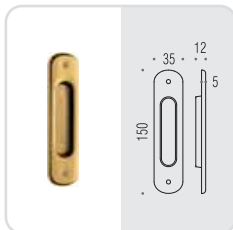

## CD 211 CF

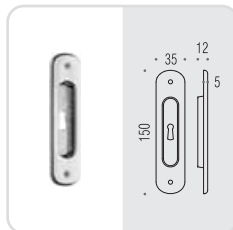

# cd311 - cd511

Design: Colombo Design

MISURA FRESATA 28 x 113 x 8mm  
MILING SIZE 28 x 113 x 8mm

Materiale: Ottone  
Material: Brass



**OL**  
Oroplus

**OM**  
Oromat  
Matt gold



**CR**  
Cromo  
Chrome



**CM**  
Cromat  
Matt chrome

**NI**  
Nikelmat  
Matt nickel

**BR**  
Bronzo  
Bronze

**BA**  
Bronzo antico  
Antique bronze

**OA**  
Ottone antico  
Antique brass

## CD 311

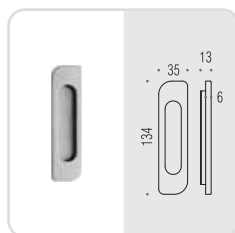

## CD 311 CF

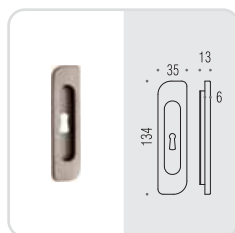

## CD 511

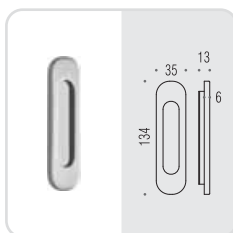

## CD 511 CF

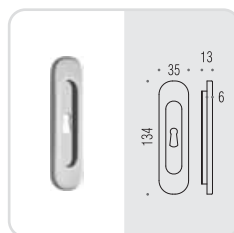

# cb111

Design: Carlo Bartoli

MISURA FRESATA 34 x 105 x 10mm  
MILING SIZE 34 x 105 x 10mm

Materiale: Cromall®  
Material: Cromall®



## CB 111

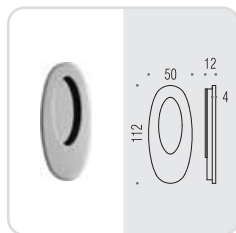

## CB 111 CF

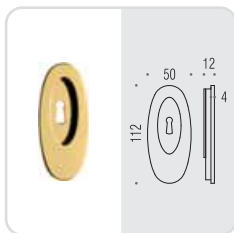

# id411

Design: Colombo Design

MISURA FRESATA 28 x 113 x 8mm  
MILING SIZE 28 x 113 x 8mm

Materiale: Ottone  
Material: Brass



**OL**  
Oroplus

**OM**  
Oromat  
Matt gold



**CR**  
Cromo  
Chrome



**CM**  
Cromat  
Matt chrome



**VL**  
Vintage



**VM**  
Vintage Mat

**NI**  
Nikelmat  
Matt nickel

## ID 411

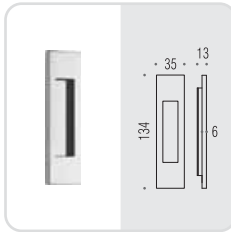

## ID 411 CF

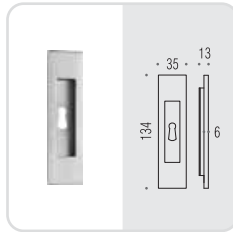

# lc111

Design: Luca Colombo

MISURA FRESATA 38 x 98 x 13mm  
MILING SIZE 38 x 98 x 13mm

Materiale: Cromal®  
Material: Cromal®



**OL**  
Oroplus



**CR**  
Cromo  
Chrome



**CM**  
Cromat  
Matt chrome

## LC 111

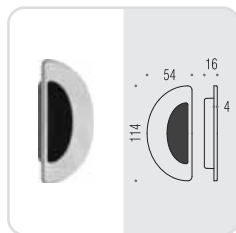

## LC 111 CF

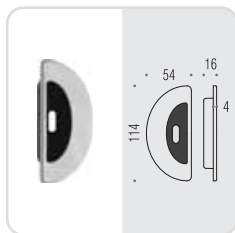





# APPENDITUTTO

## COAT HANGERS

# alizé

Design: Angeletti Ruzza Design

Materiale: Ottone  
Material: Brass



**CR**  
Cromo  
Chrome

**AR 37**

CR

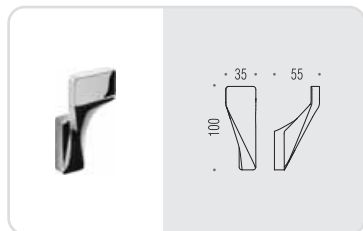

# club

Design: Carlo Bartoli

Materiale: Ottone  
Material: Brass



**OL**  
Oroplus



**CR**  
Cromo  
Chrome



**CM**  
Cromat  
Matt chrome

## CB 37

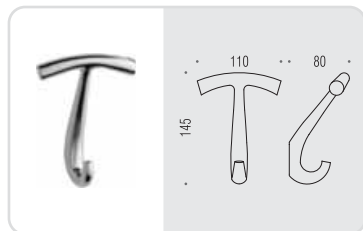

# forever

Design: Luca Colombo

Materiale: Ottone  
Material: Brass



**CR**  
Cromo  
Chrome

**LC 67**

CR

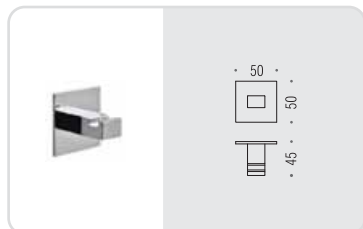

Fissaggio a muro e vetro ottenuto con uno speciale nastro biadesivo in schiuma acrilica ad alte prestazioni (3M™ VHB™).

Attenzione: Si consiglia l'applicazione dei pezzi su superfici particolarmente ruvide o poco compatte, così come suintonaci o muri grezzi.

Wall and glass fixing with a special high performance double sided acrylic foam tape (3M™ VHB™).  
Attention: we do not recommend the application of the pieces on surfaces particularly rough, as well as on painted walls.



# golf

Design: Angeletti Ruzza Design

Materiale: Ottone  
Material: Brass



**OL**  
Oroplus

**NI**  
Nikelmat  
Matt nickel

**AR 17**

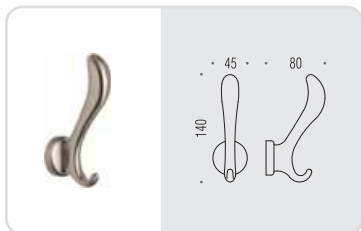

# hermitage

Classic Line

Materiale: Ottone  
Material: Brass



**HPS**  
Zirconium  
gold HPS



**CR**  
Cromo  
Chrome

**OA**  
Ottone antico  
Antique brass

## LC 77

HPS CR OA

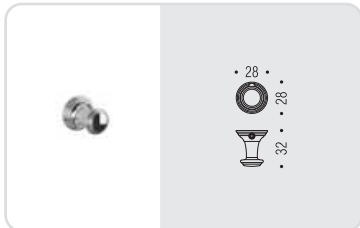

## LC 87

HPS CR OA

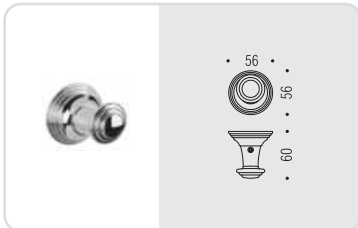

# hook

Design: Alberto Meda

Materiale: Ottone  
Material: Brass



## AM 17 (HOOK 1)

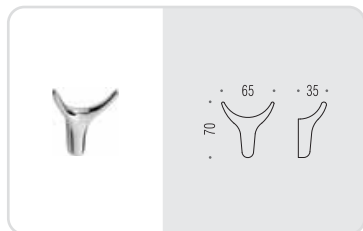

## AM 27 (HOOK 2)

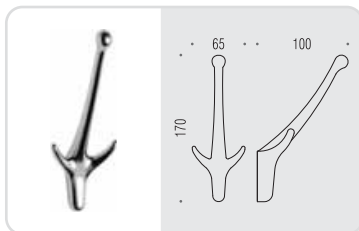

# khala

Design: Makio Hasuike

Materiale: Ottone  
Material: Brass



**CR**  
Cromo  
Chrome



**CM**  
Cromat  
Matt chrome

## MH 17

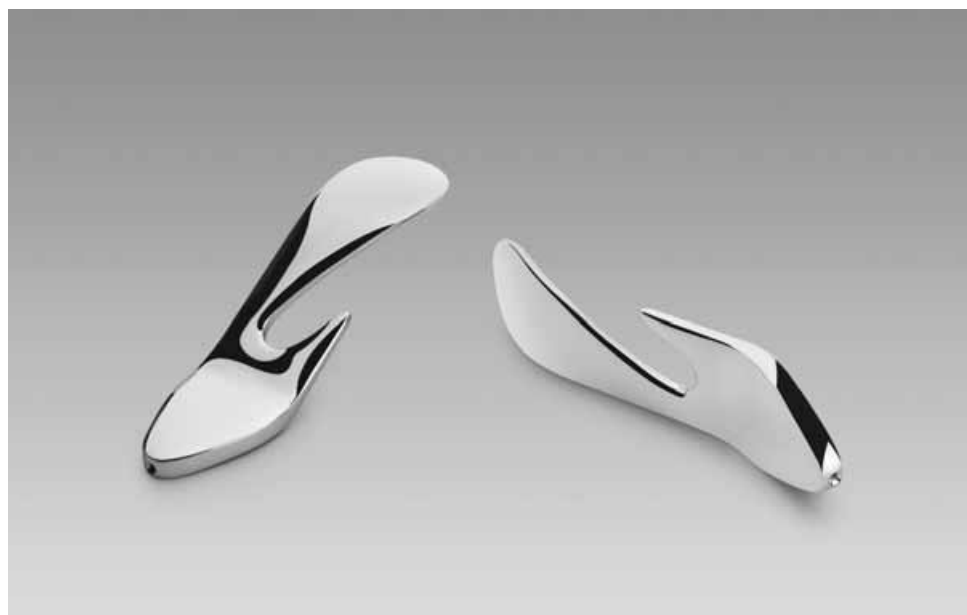
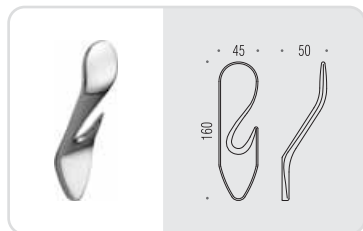



# land

Design: **TEAM 3**

Materiale: Ottone  
Material: Brass



**CR**  
Cromo  
Chrome

## CD 67

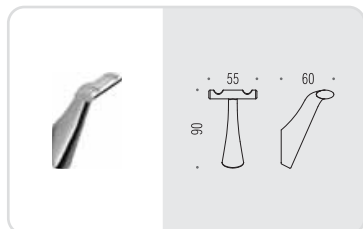

## CD 77

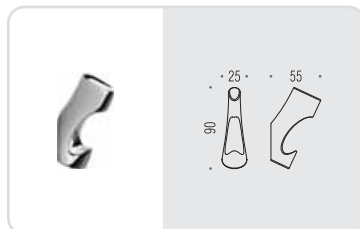

# link

Design: Angeletti Ruzza Design

Materiale: Ottone  
Material: Brass

 **CR**  
Cromo  
Chrome

**AR 27**

**CR**



# look

Design: Luca Colombo

Materiale: Cromall®  
Material: Cromall®



**CR**  
Cromo  
Chrome

**LC 27**

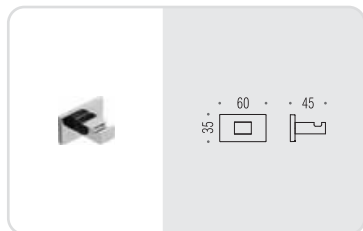

**LC 37**

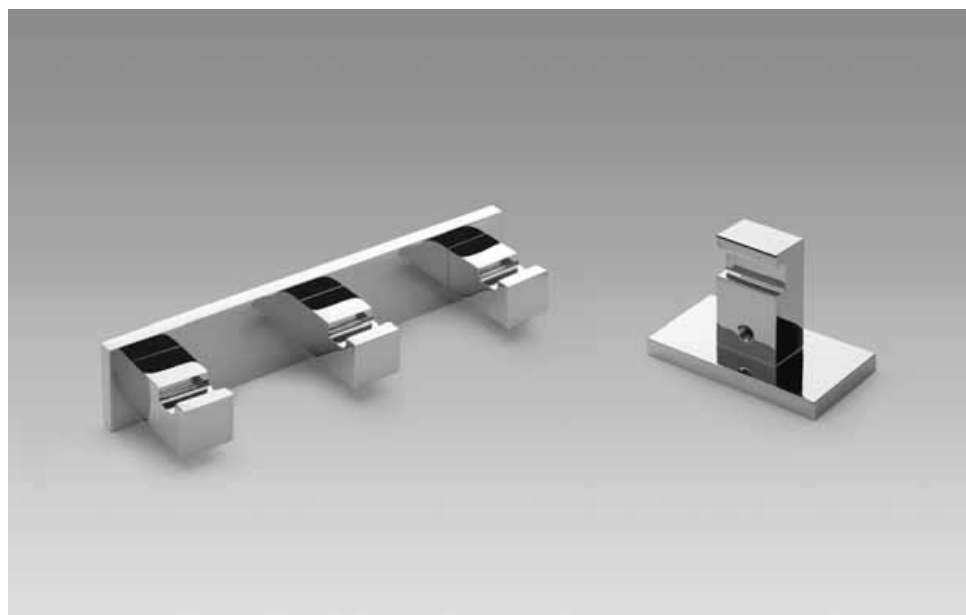
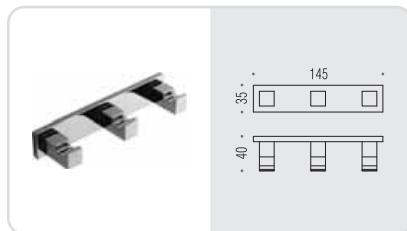

# lulù

Design: Luca Colombo

Materiale: Ottone  
Material: Brass



**HPS**  
Zirconium  
gold HPS



**CR**  
Cromo  
Chrome

**LC 47**

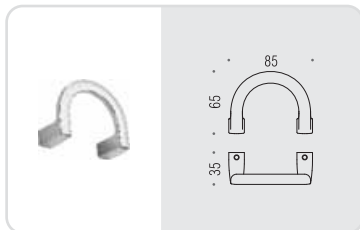

**LC 57**

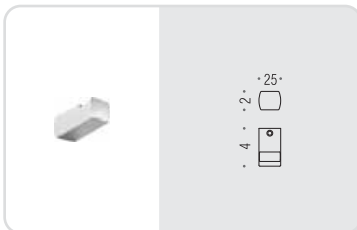

# melò

Design: Ambrogio Rossari

Materiale: Cromall®  
Material: Cromall®



**CR**  
Cromo  
Chrome

**RA 17**

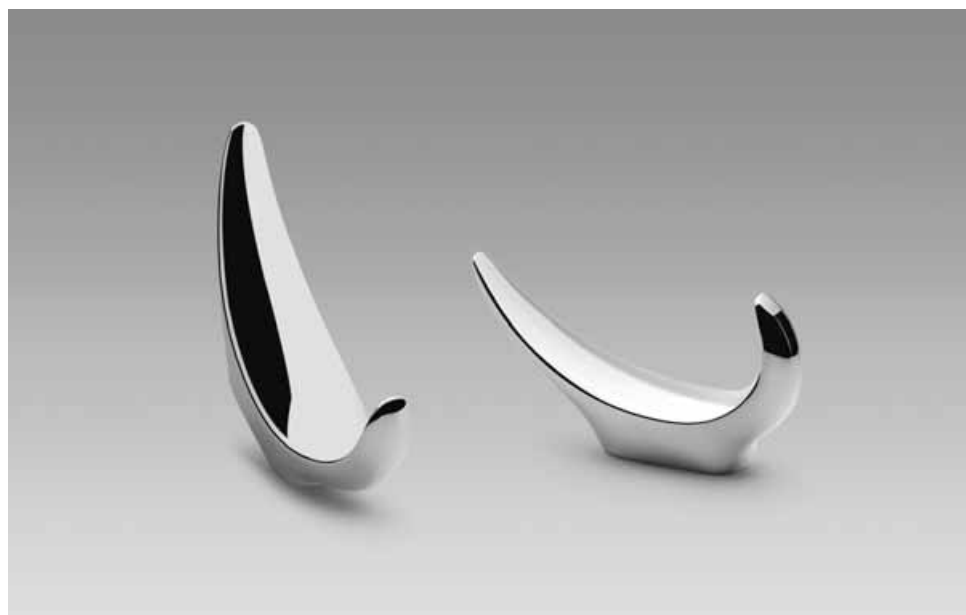
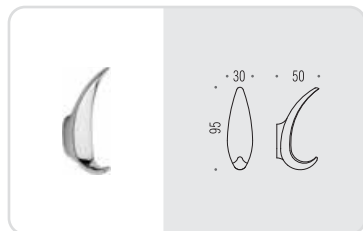

# nordic

Design: Efrem Bonacina e Giovanni Moro

Materiale: Cromall®  
Material: Cromall®



**CR**  
Cromo  
Chrome

**EB 17**

CR

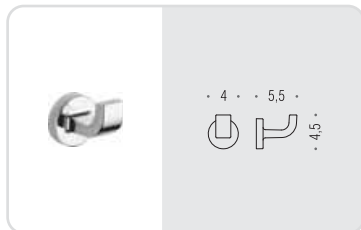

**EB 27**

CR

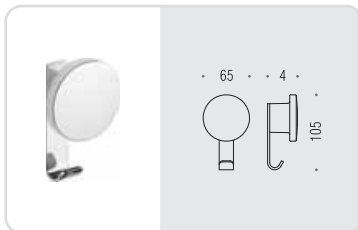

# over

Design: Efrem Bonacina e Giovanni Moro

Materiale: Acciaio Inox AISI 316 L  
Material: AISI 316 L Inox Stainless Steel



**SS**  
Satinata  
Satin

**GM 17**

SS

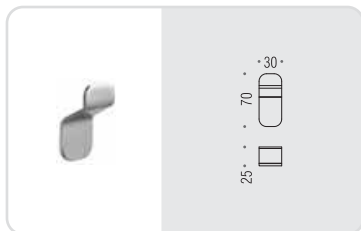

Fissaggio a muro e vetro ottenuto con uno speciale nastro biadesivo in schiuma acrilica ad alte prestazioni (3M™ VHB™).

**Attenzione:** Si sconsiglia l'applicazione dei pezzi su superfici particolarmente ruvide o poco compatte, così come su intonaci o muri grezzi.

Wall and glass fixing with a special high performance double sided acrylic foam tape (3M™ VHB™).  
**Attention:** we do not recommend the application of the pieces on surfaces particularly rough, as well as on painted walls.

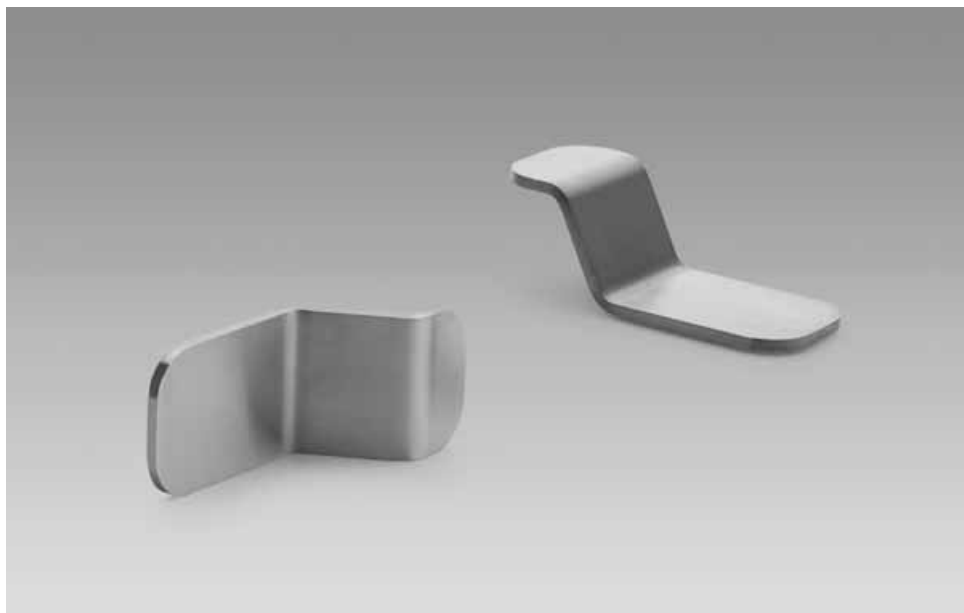

# plus

Design: Piet Billekens

Materiale: Ottone  
Material: Brass



**CR**  
Cromo  
Chrome

**PB 17**

CR

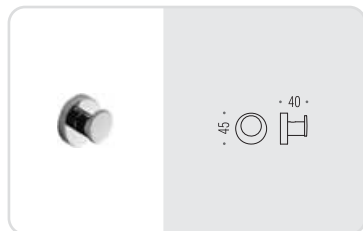



# polo

Design: Luca Colombo

Materiale: Cromal®  
Material: Cromal®



**CR**  
Cromo  
Chrome

**LC 17**

CR

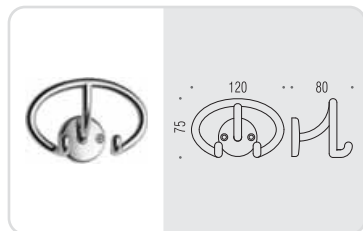

# portofino

Design: Classic Line

Materiale: Ottone  
Material: Brass



## CD 87

CR

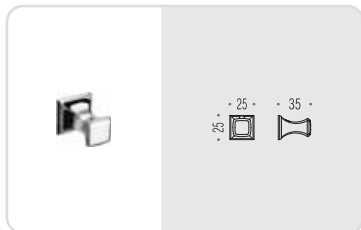

## CD 97

CR

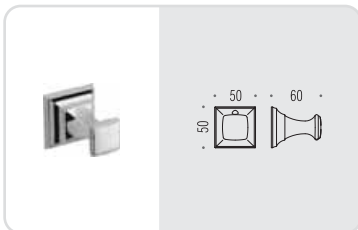

# time

Design: Colombo Design

Materiale: Ottone  
Material: Brass



**CD 17**

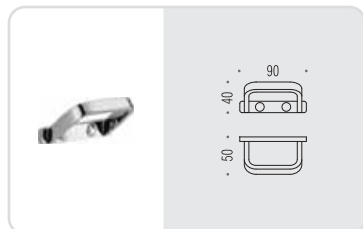

**CD 27**

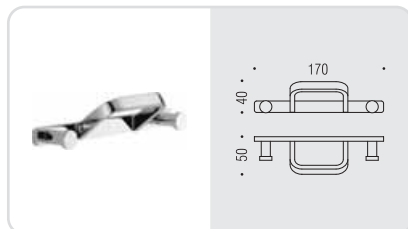

# time

Design: Colombo Design

Materiale: Ottone  
Material: Brass



**CR**  
Cromo  
Chrome

## CD 47



## CD 37

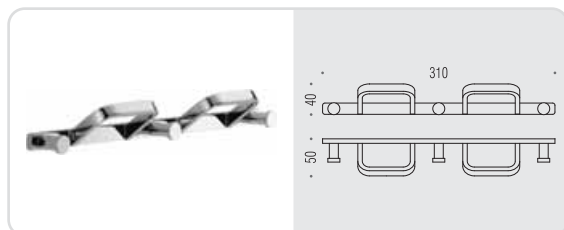

## CD 57

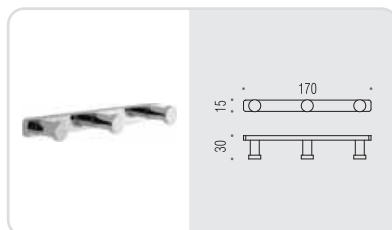

# trio

Design: Carlo Bartoli

Materiale: Cromall®/Ottone  
Material: Cromall®/Brass



**CB 17**

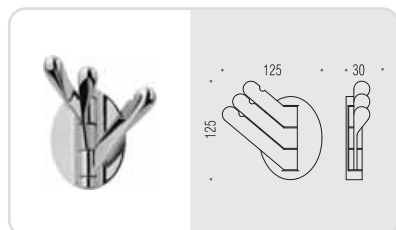



**PROGRAMMA**  
**BLINDATE**  
A R M O R E D  
D O O R P R O G R A M

# mostrine

ROSE PLATE  
Design: Colombo Design

Materiale: Ottone  
Material: Brass



**HPS**  
Zirconium  
gold HPS



**OL**  
Oroplus

**OM**  
Oromat  
Matt gold



**CR**  
Cromo  
Chrome



**CM**  
Cromat  
Matt chrome

**NI**  
Nikelmat  
Matt nickel

**BR**  
Bronzo  
Bronze

**NM**  
Neromat  
Matt black

## PB 01

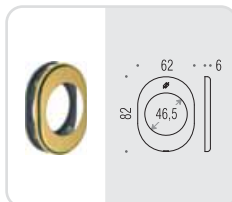

Rosetta con sottorosetta in nylon  
compresa di 5 viti di fissaggio  
Brass rose supplied with nylon underconstruction  
and 5 fixing screws

## PB 01 DG

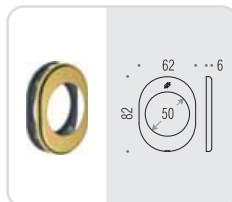

Rosetta con sottorosetta in nylon  
per defedter ø50mm  
compresa di 5 viti di fissaggio  
Brass rose supplied with nylon underconstruction  
for defedter ø50mm and 5 fixing screws

## PB 02

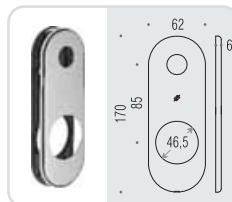

Placca interasse 85mm con sottoplacca  
in nylon compresa di 5 viti di fissaggio  
(utilizzabile solo con inserti PB06 e PB07)  
Brass plate 85 mm distance, supplied with nylon  
underconstruction and 5 fixing screws (use only  
with underconstruction PB06 and PB07)

## PB 02 Y

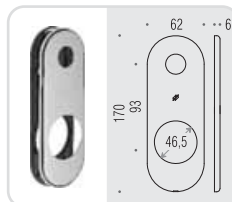

Placca interasse 93mm con sottoplacca  
in nylon compresa di 5 viti di fissaggio  
(utilizzabile solo con inserti PB05 e PB08)  
Brass plate 93 mm distance, supplied with nylon  
underconstruction and 5 fixing screws (use only  
with underconstruction PB05 and PB08)





# mostrine

ROSE PLATE  
Design: Colombo Design

Materiale: Ottone  
Material: Brass



## PB 01/Q

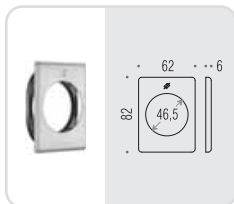

Rosetta quadrata con sottorosetta in nylon compressa di 5 viti di fissaggio.  
Square brass rose supplied with nylon underconstruction and 5 fixing screws

## PB 01 DG/Q

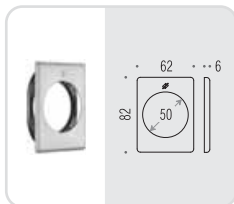

Rosetta quadrata con sottorosetta in nylon per defender ø50mm compressa di 5 viti di fissaggio.  
Square brass rose supplied with nylon underconstruction for defender ø50mm and 5 fixing screws.

## PB 02/Q

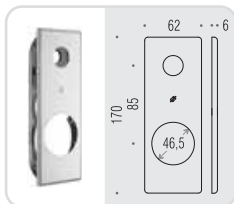

Placca quadrata int. 85mm con sottoplacca in nylon compressa di 5 viti di fissaggio (utilizzabile solo con inserti PB06 e PB07)  
Square brass plate 85 mm distance, supplied with nylon underconstruction and 5 fixing screws (use only with underconstruction PB06 and PB07)

## PB 02 Y/Q

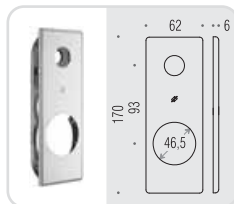

Placca quadrata int. 93mm con sottoplacca in nylon compressa di 5 viti di fissaggio (utilizzabile solo con inserti PB05 e PB08)  
Square brass plate 93 mm distance, supplied with nylon underconstruction and 5 fixing screws (use only with underconstruction PB05 and PB08)



# inserti per mostrine

UNIVERSAL  
UNDERCONSTRUCTION

Design: Colombo Design

Materiale: Nylon nero  
Material: Black nylon

**NE**  
Nero  
Black

## PB 03

NE

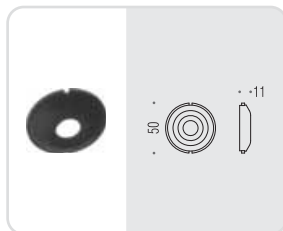

Inserto maniglia  
(possibilità montaggio con molla Ø45 mm)  
Underconstruction for level handle rose  
(Ø45mm spring installation possible)

## PB 04

NE

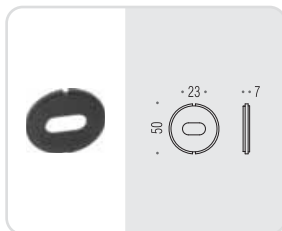

Inserto limitatore d'apertura  
Underconstruction for opening limiting device

## PB 05

NE

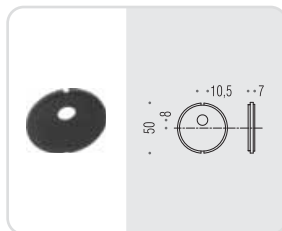

Inserto per cilindro con pomolo  
Underconstruction for knob cylinder

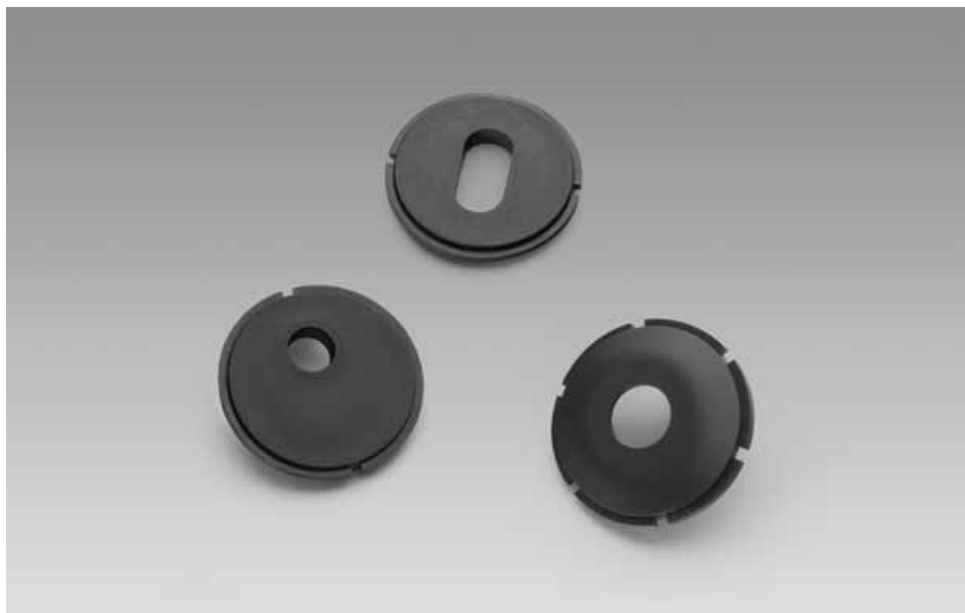

# inserti per mostrine

UNIVERSAL  
UNDERCONSTRUCTION

Design: Colombo Design

Materiale: Nylon nero  
Material: Black nylon

**NE**  
Nero  
Black

## PB 06

NE

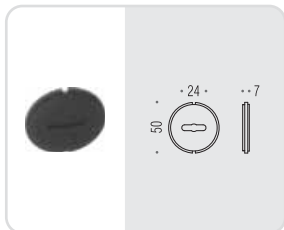

Inserto doppia mappa universale  
compreso di copritoppa  
Underconstruction for double ward universal key  
with key cover

## PB 07

NE

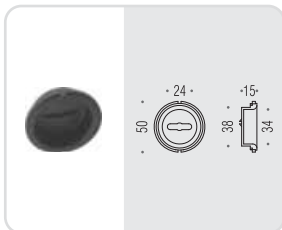

Inserto doppia mappa concavo universale  
compreso di copritoppa  
Underconstruction for double ward universal key  
with key cover

## PB 08

NE

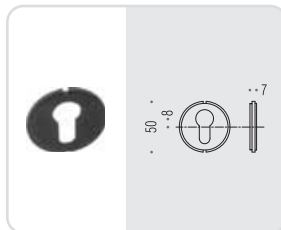

Inserto foro yale  
Underconstruction for yale key hole



# pomolino

Design: Colombo Design

KNOB SET

Materiale: Ottone

Material: Brass



**HPS**  
Zirconium  
gold HPS



**OL**  
Oroplus

**OM**  
Oromat  
Matt gold



**CR**  
Cromo  
Chrome



**CM**  
Cromat  
Matt chrome

**NI**  
Nikelmat  
Matt nickel

**BR**  
Bronzo  
Bronze

**NM**  
Neromat  
Matt black

## PB 09

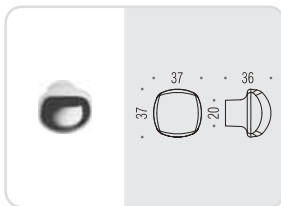

Pomolino Ø35mm per limitatore d'apertura  
(e/o per cilindro) cava interna quadro  
8mm - Ø9mm

Knob set Ø35mm for opening limiting device  
(also for cylinder) spindle 8mm - thread 9mm

## PB 09/Q

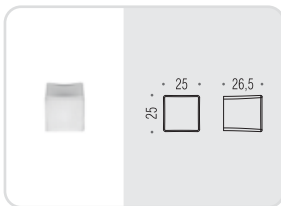

Pomolino quadrato per limitatore d'apertura  
(e/o per cilindro) cava interna quadro 8mm

Square knob set for opening limiting device  
(also for cylinder) spindle 8mm



# kit SR (bocchetta di protezione per cilindro)

Design: Colombo Design

SR KIT (escutcheons cylinder protection)

Materiale: Ottone  
Material: Brass



**HPS**  
Zirconium  
gold HPS



**CR**  
Cromo  
Chrome



**CM**  
Cromat  
Matt chrome

**BR**  
Bronzo  
Bronze

## KIT SR 73 WP

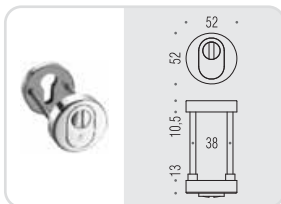

Interasse 38mm  
Viti M6x80 TPS+  
Centre 38mm  
Screws 6MA

## KIT SR 93 WP

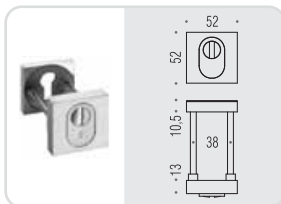

Interasse 38mm  
Viti M6x80 TPS+  
Centre 38mm  
Screws 6MA





# COMPLEMENTI

## COMPLEMENTS

# dispositivi di sicurezza

SECURITY WINDOWS SETS

Materiale: Cromall®  
Material: Cromall®



**OL**  
Oroplus



**CR**  
Cromo  
Chrome



**CM**  
Cromat  
Matt chrome

## CD 42 DK Z Design: Colombo Design



DREH-KIPP Robot con dispositivo a pulsante di sicurezza, con movimento DK (DK Q8 L) incluso. Quadro 7x40.

Carico di rottura **40 N·m**

Button-locked security DK window handle set, DK mechanism included (DK Q8 L).

Spindle 7x40, Breaking load **40 N·m**

## CD 92 DK Z Design: Colombo Design

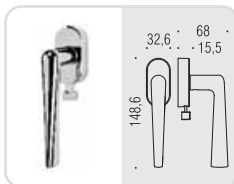

DREH-KIPP Robotre con dispositivo a pulsante di sicurezza, con movimento DK (DK Q8 L) incluso. Quadro 7x40.

Carico di rottura **40 N·m**

Button-locked security DK window handle set, DK mechanism included (DK Q8 L).

Spindle 7x40, Breaking load **40 N·m**

## ID 42 DK Z Design: Colombo Design

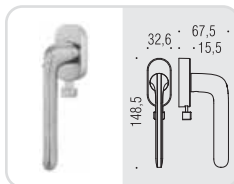

DREH-KIPP Roboquattro con dispositivo a pulsante di sicurezza, con movimento DK (DK Q8 L) incluso. Quadro 7x40.

Carico di rottura **40 N·m**

Button-locked security DK window handle set, DK mechanism included (DK Q8 L).

Spindle 7x40, Breaking load **40 N·m**



premere pulsante  
press button



rotazione 90°  
apertura finestra  
spin 90° to open  
window



premere pulsante  
press button



rotazione 90°  
anta ribalta  
spin 90° for vertical  
partial opening





# dispositivi di sicurezza

SECURITY WINDOWS SETS

Materiale: Ottone/Cromall®/Acciaio (DK Z) - Cromall®/Acciaio (DK Z Q)  
 Material: Brass/Cromall®/Steel (DK Z) - Cromall®/Steel (DK Z Q)



**HPS**  
Zirconium  
gold HPS



**OL**  
Oroplus

**OM**  
Oromat  
Matt gold



**HPS/1**  
Zirconium  
stainless-steel HPS



**CR**  
Cromo  
Chrome



**CM**  
Cromat  
Matt chrome

**NI**  
Nikelmat  
Matt nickel

**BR**  
Bronzo  
Bronze

**CD 02 DK Z** Design: Colombo Design

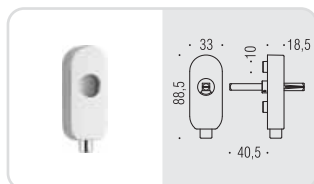

Dispositivo a pulsante di sicurezza, adatto a tutti i modelli di maniglie con movimento DK (DK Q8 L) incluso. Quadro 7x40.

Carico di rottura **60 N·m**

Button-locked security DK window handle set suitable for all handles, DK mechanism included (DK Q8 L), Spindle 7x40.

Breaking load **60 N·m**

**CD 02 DK Z/Q** Design: Colombo Design

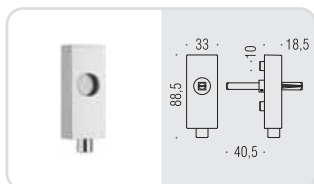

Dispositivo a pulsante di sicurezza quadrato, adatto a tutti i modelli di maniglie con movimento DK (DK Q8 L) incluso. Quadro 7x40.

Carico di rottura **60 N·m**

Button-locked security DK window handle set suitable for all handles, DK mechanism included (DK Q8 L), Spindle 7x40.

Breaking load **60 N·m**



premere  
pulsante  
press button



rotazione 90°  
apertura finestra  
spin 90° to open  
window



premere  
pulsante  
press button



rotazione 90°  
anta ribalta  
spin 90° for vertical  
partial opening



# dispositivi antieffrazione

SECURITY WINDOWS SETS

Materiale: Ottone/Acciaio  
Material: Brass/Steel



**HPS**  
Zirconium  
gold HPS



**OL**  
Oroplus



**CR**  
Cromo  
Chrome



**CM**  
Cromat  
Matt chrome

## CD 02 DK LOCK Design: Colombo Design

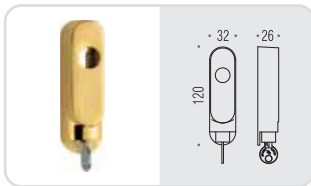

### UNI ENV 1627:2011

Dispositivo con sistema di bloccaggio a chiave (cilindro KA stessa cifratura) per antieffrazione, adatto a tutti i modelli di maniglie con movimento DK (DK 40 D) incluso. Quadro 7x40. Carico di rottura **100 N·m**  
Key-locked security DK window handle set (KA cylinder same key code) suitable for all handles, DK mechanism included (DK 40 D), Spindle 7x40. Breaking load **100 N·m**



premere chiave  
per bloccare  
serratura  
press key to block  
lock



maniglia  
sbloccata  
unblocked  
handle



ruotare chiave  
per sbloccare  
serratura  
rotate key in order  
to unblock lock



rotazione 90°  
apertura finestra  
spin 90° to open  
window



premere chiave  
per bloccare  
serratura  
press key to block  
lock



# fermaporta DOOR STOPPERS

Materiale: Ottone (CD 112, CD 312, CD 412) - Cromall® (LC 112)  
 Material: Brass (CD 112, CD 312, CD 412) - Cromall® (LC 112)



**OL**  
Oroplus

**OM**  
Oromat  
Matt gold



**CR**  
Cromo  
Chrome



**CM**  
Cromat  
Matt chrome

**NI**  
Nikelmat  
Matt nickel

**BR**  
Bronzo  
Bronze

**BA**  
Bronzo antico  
Antique bronze



**VL**  
Vintage



**VM**  
Vintage Mat

**CD 112** Design: Colombo Design

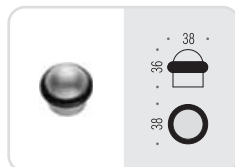

Il gommino è sempre di colore nero  
 Black rubber ring

**CD 312** Design: Colombo Design

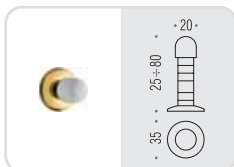

Regolabile in altezza da 25 a 80mm.  
 Il gommino superiore è sempre di colore bianco.  
 Adjustable from 25 to 80mm. White rubber ring.

**CD 412** Design: Colombo Design

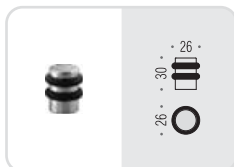

Il gommino è sempre di colore nero  
 Black rubber ring

**LC 112** Design: Luca Colombo

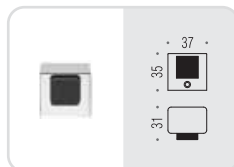

La gomma è di colore nero  
 Black rubber.



# chiavi KEYS

Materiale: Ottone  
Material: Brass



**OL**  
Oroplus

**OM**  
Oromat  
Matt gold



**CR**  
Cromo  
Chrome



**CM**  
Cromat  
Matt chrome

**NI**  
Nikelmat  
Matt nickel

**BR**  
Bronzo  
Bronze

**BA**  
Bronzo antico  
Antique bronze

**OA**  
Ottone antico  
Antique brass

**NM**  
Neromat  
Matt black

**AM 14** Design: Alberto Meda

OL OM CR CM NI NM

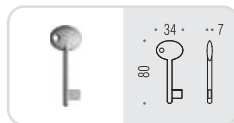

**AR 14** Design: Angeletti Ruzza Design

OL BR OA

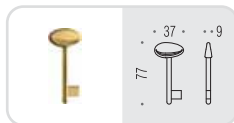

**CB 24** Design: Carlo Bartoli

OL CM



**CD 14** Design: Colombo Design

OL OM CR CM BR BA OA

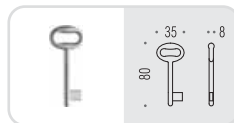

**LC 14** Design: Luca Colombo

OL OM CR CM NI

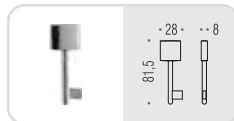

**LC 24** Design: Luca Colombo

CR CM

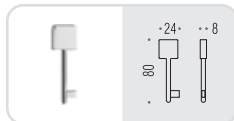

# nottolini

TOILET ROSES

Materiale: Ottone/Cromal®  
Material: Brass/Cromal®



**HPS**  
Zirconium  
gold HPS



**OL**  
Oroplus

**OM**  
Oromat  
Matt gold



**HPS/1**  
Zirconium  
SS HPS



**CR**  
Cromo  
Chrome



**CM**  
Cromat  
Matt chrome



**VL**  
Vintage



**VM**  
Vintage Mat

**NI**  
Nikelmat  
Matt nickel

**BR**  
Bronzo  
Bronze

**BA**  
Bronzo antico  
Antique bronze

**OA**  
Ottone antico  
Antique brass

**NM**  
Neromat  
Matt black

**BI**  
Bianco  
White

**BT 19 BZG 6/8**



OL CR CM VL VM

**CD 39 BZG 6/8**



CR CM

**CD 49 BZG G 6/8**



OL OM HPS1 CR CM NI

**CD 69 BZG 6/8**



HPS OL OM CR CM NI BR NM BI

**CD 69 BZG G 6/8**



OL CR CM NI BR BA OA

**CD 79 BZG 6/8**



OL BR



# nottolini

TOILET ROSES

Materiale: Ottone/Cromall®  
Material: Brass/Cromall®



**OL**  
Oroplus



**CR**  
Cromo  
Chrome



**CM**  
Cromat  
Matt chrome



**VL**  
Vintage



**VM**  
Vintage Mat



**GL**  
Grafite  
Graphite



**GM**  
Grafite Mat  
Matt graphite

## DB 19 BZG 6/8



OL CR BR

## FF 19 BZG 6/8



CR CM

## FF 29 BZG 6/8

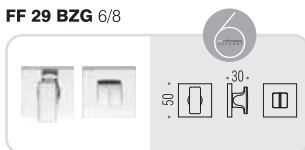

CR CM VL VM

## MM 29 BZG 6/8



CR CM

## MR 29 BZG G 6/8



CR CM

## PT 19 BZG 6/8



OL CR CM VL VM

## SE 19 BZG 6/8



CR CM GL GM



# libero/occupato

TOILET ROSES WITH PRIVACY INDICATOR

Materiale: Ottone/Cromall®  
Material: Brass/Cromall®



## CD 49 BZG H 6



## CD 69 BZG H 6



## MM 19 BZG H 6

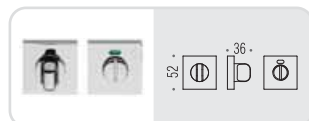

## MR 19 BZG G 6/8



## PT 19 BZG H 6



## SE 19 BZG H 6/8



# bocchette tonde

ROUND ESCUTCHEONS

Materiale: Ottone/Cromall®  
Material: Brass/Cromall®



**HPS**  
Zirconium  
gold HPS



**OL**  
Oroplus

**OM**  
Oromat  
Matt gold



**HPS/1**  
Zirconium  
SS HPS



**CR**  
Cromo  
Chrome



**CM**  
Cromat  
Matt chrome

**NI**  
Nikelmat  
Matt nickel

**BR**  
Bronzo  
Bronze

**BA**  
Bronzo antico  
Antique bronze

**OA**  
Ottone antico  
Antique brass

**NM**  
Neromat  
Matt black

**BI**  
Bianco  
White



**GL**  
Grafite  
Graphite



**GM**  
Grafite Mat  
Matt graphite

**CD 33**



HPS CM NI

**CD 43 G B**

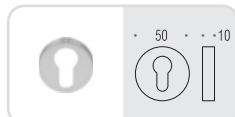

HPS OM HPS/1 CR CM NI

**CD 63**

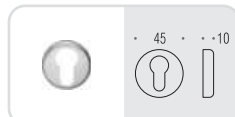

HPS OL OM HPS/1 CR CM  
NI BR BA NM BI

**CD 63 G B**

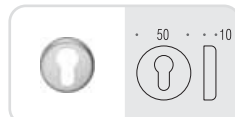

HPS OL OM HPS/1 CR CM  
NI BR BA OA

**CD 1003**



OL BR

**DB 13**

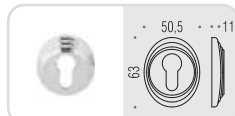

OL CR BR

**FF 13**



CR CM





# bocchette quadre SQUARE ESCUTCHEONS

Materiale: Ottone/Cromall®  
Material: Brass/Cromall®



**HPS**  
Zirconium  
gold HPS



**OL**  
Oroplus



**CR**  
Cromo  
Chrome



**CM**  
Cromat  
Matt chrome



**VL**  
Vintage



**VM**  
Vintage Mat

**BT 13**



HPS1 OL CR CM VL VM

**FF 23**

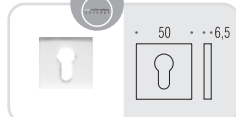

CR CM VL VM

**MM 13**



CR CM

**PT 13**



OL CR CM VL VM

**MR 13**



CR CM

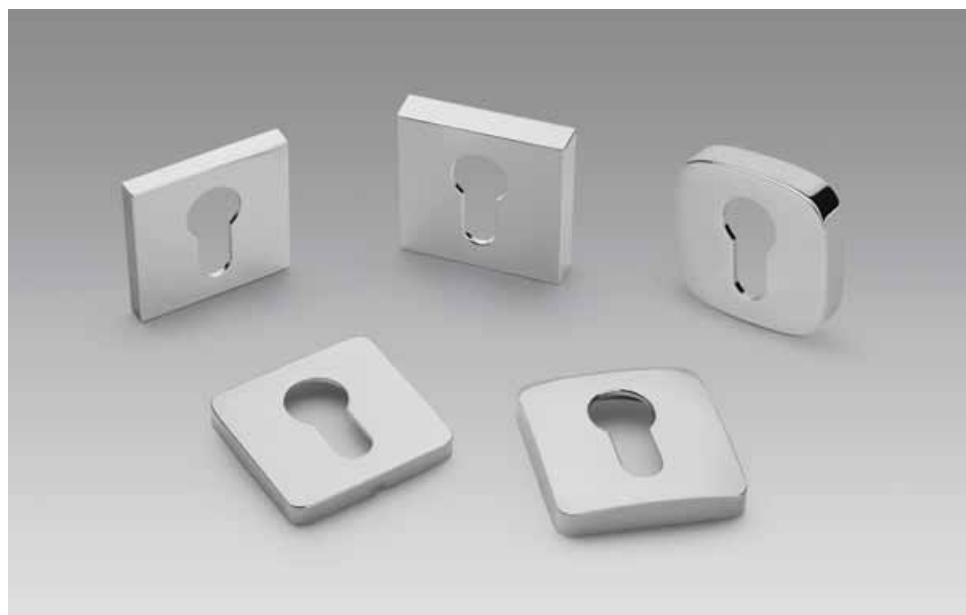

# rosette strette

OVAL ROSE

Materiale: Ottone  
Material: Brass

Adattabili a tutti i modelli di maniglie  
Suitable for all types of door handles



**HPS**  
Zirconium  
gold HPS



**OL**  
Oroplus

**OM**  
Oromat  
Matt gold



**HPS/1**  
Zirconium  
SS HPS



**CR**  
Cromo  
Chrome



**CM**  
Cromat  
Matt chrome



**VL**  
Vintage



**VM**  
Vintage Mat

**NI**  
Nikelmat  
Matt nickel

**BR**  
Bronzo  
Bronze

**BA**  
Bronzo antico  
Antique bronze

**OA**  
Ottone antico  
Antique brass

**NM**  
Neromat  
Matt black

**BI**  
Bianco  
White



**GL**  
Grafite  
Graphite



**GM**  
Grafite Mat  
Matt graphite

## CD 73 RS/M

Rosetta stretta con molla  
Oval escutcheon spring loaded

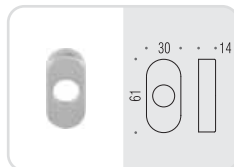

## CD 73 RS

Rosetta stretta senza molla  
Oval escutcheon without spring

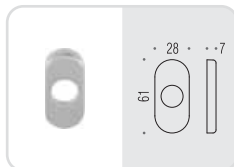

## MM 13 RS

Rosetta stretta quadrata senza molla  
Square escutcheon without spring

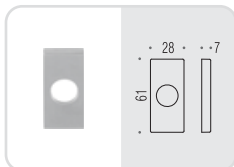

## MM 13 RS/M

Rosetta stretta quadrata con molla  
Square escutcheon spring loaded

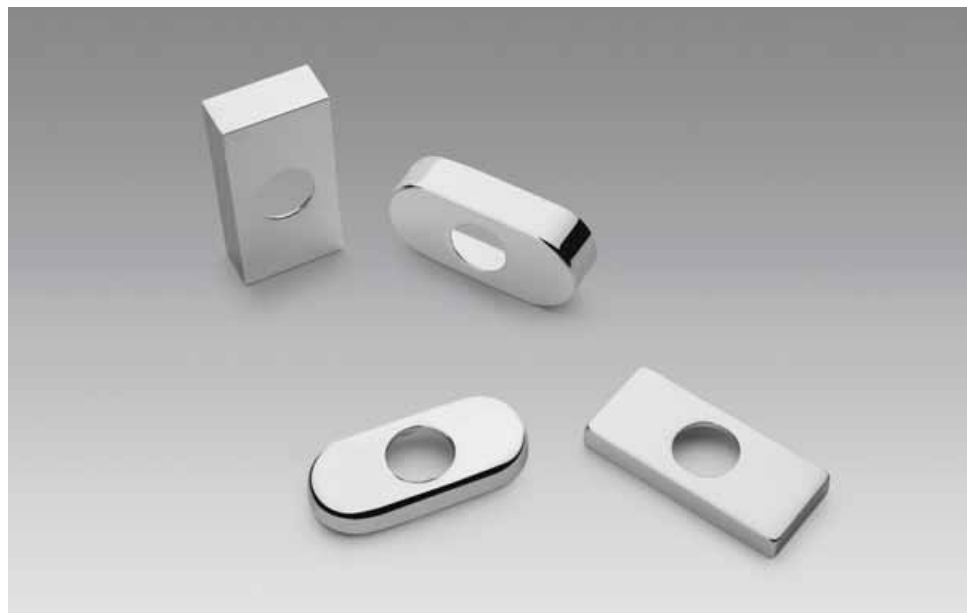
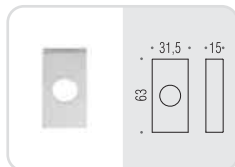

# bocchette strette

OVAL ESCUTCHEONS

Materiale: Ottone  
Material: Brass

Adattabili a tutti i modelli di maniglie  
Suitable for all types of door handles

 <b>HPS</b> Zirconium gold HPS	 <b>OL</b> Oroplus	<b>OM</b> Oromat Matt gold	 <b>HPS/1</b> Zirconium SS HPS	 <b>CR</b> Cromo Chrome	 <b>CM</b> Cromat Matt chrome		
 <b>VL</b> Vintage	 <b>VM</b> Vintage Mat	<b>NI</b> Nikelmat Matt nickel	<b>BR</b> Bronzo Bronze	<b>BA</b> Bronzo antico Antique bronze	<b>OA</b> Ottone antico Antique brass	<b>NM</b> Neromat Matt black	<b>BI</b> Bianco White
 <b>GL</b> Grafite Graphite	 <b>GM</b> Grafite Mat Matt graphite						

## CD 73 BS

Rosetta stretta con molla  
Oval escutcheon spring loaded

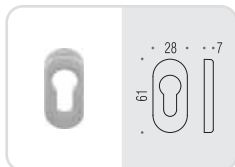

## CD 73 BS BB

Rosetta stretta senza molla  
Oval escutcheon without spring

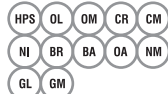
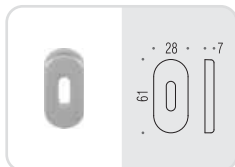

## MM 13 BS

Rosetta stretta quadra senza molla  
Square escutcheon without spring

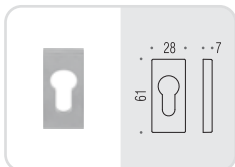

## MM 13 BS BB

Rosetta stretta quadra con molla  
Square escutcheon spring loaded

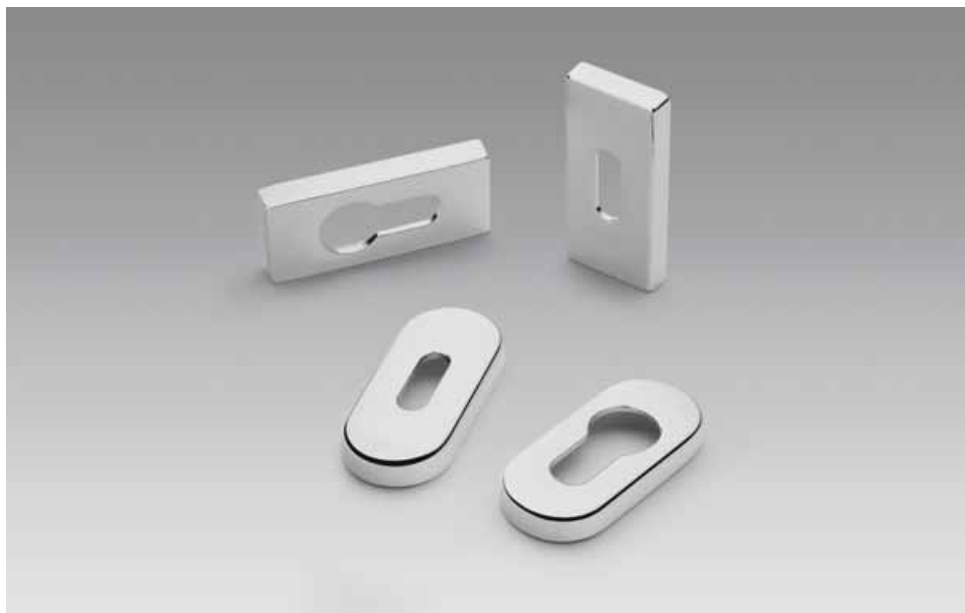
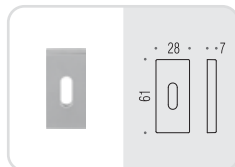

# glossario GLOSSARY

	ITALIANO	ENGLISH	FRANÇAIS	DEUTSCHE	ESPAÑOL
MATERIALE MATERIAL	Cromall®	Cromall® alloy	Alliage Cromall®	Cromall® Legierung	Aleación Cromall®
	Ottone	Brass	Laiton	Messing	Latòn
	Tecnopolimero	Technopolymer	Technopolymer	Technopolymer	Technopolymer

	ITALIANO	ENGLISH	FRANÇAIS	DEUTSCHE	ESPAÑOL
COLORIBASE MAIN COLORS	Bianco	White	Blanche	Weiss	Blanco
	Bronzo	Bronze	Bronze	Bronziert	Bronce
	Bronzo Antico	Antique Bronze	Bronze ancien	Bronze Antik	Bronce antiguo
	 Cromat	 Mat chrome	 Chromé mate	 Chrom matt	 Cromado-mate
	 Cromo	 Chrome	 Chromé	 Chrom	 Cromado
	Neromat	Mat black	Noire mate	Schwarz matt	Negro-mate
	Nikelmat	Mat nickel	Nikel-mat	Matt-Nickel	Nequel mate
	 Oroplus	 Oroplus	 Oroplus	 Oroplus	 Oroplus
	Oromat	Mat gold	Or-mat	Matt-Vergoldet	Latón mate
	Ottone antico	Antique brass	Laiton ancien	Altmessing	Latón antiguo
	 Stainless-Steel	 Stainless-Steel	 Stainless-Steel	 Stainless-Steel	 Stainless-Steel
	 Zirconium Gold	 Zirconium Gold	 Zirconium Gold	 Zirconium Gold	 Zirconium Gold
	 Vintage	 Vintage	 Vintage	 Vintage	 Vintage
	 Vintage Mat	 Vintage Mat	 Vintage Mat	 Vintage Mat	 Vintage Mate
	 Grafite	 Graphite	 Graphite	 Graphit	 Grafito
	 Grafite Mat	 Matt Graphite	 Graphite Mat	 Graphit Matt	 Grafito Mate

	ITALIANO	ENGLISH	FRANÇAIS	DEUTSCHE	ESPAÑOL
COLORILEGNO WOOD COLORS	Carbonium	Carbonium	Carbonium	Carbonium	Carbonium
	Ebano Makassar	Makassar Ebony	Ébène Makassar	Makassar Ebenholz	Ebano Makassar
	Palissando	Rosewood	Palissandre	Palisanderholz	Palisandro
	Pau Violetto	Pau Violetto	Pau Violetto	Pau Violetto	Pau Violetto
	Pero	Pear wood	Poirier	Birnbaumholz	Pera
	Pero Look	Pero Look	Pero Look	Pero Look	Pero Look

	ITALIANO	ENGLISH	FRANÇAIS	DEUTSCHE	ESPAÑOL
FAMIGLIE MERCEOLOGICHE PRODUCT RANGE	Maniglie	Door-handles	Béquilles	Türdrücker	Manillas
	Pomoli	Door-knobs	Boutons	Türknoöpfe	Pomos
	Maniglioni	Pulls	Poignées	Türgriffe	Tiradores
	Maniglioni senza rosette	Pulls without roses	Poignées sans rosette	Griffe ohne Rosetten	Tirador sin roseta
	Maniglioni con rosette	Pulls with roses	Poignées avec rosette	Griffe auf Rosetten	Tirador con roseta
	Maniglioni per alzante scorrevole	Lifted sliding door pulls	Poignées pour porte coulissante qui se souleve	Hebe-Schiebetürgriffe	Tirador para puertas deslizantes
	Maniglione per coplanare	Pull for coplanar sliding doors	Poignée pour porte coulissante coplanaire	Schiebetürgriffe	Tirador para puertas deslizantes
	Battiporta	Door-knocker	Butée	Türklopfen	Picaporte
	Maniglie incasso	Groove handles	Poignée à rainure	Muschelgriffe	Tirador de ranura
	Appenditutto	Coat-hangers	Patères	Hacken	Perchas
	Programma blindate	Door armored progr.	Porte blindées	Sichereitsbeschläge	Programma blindaje
	Mostrine	Rose plates	Rosace / Plaques	Rosetten	Roseta
	Inseri per mostrine	Universal underconstruction	Sous construction Universel	Unterkonstruktionen	Roseta de empotrar
	Pomolino	Knob set	Set de poignées	Kleinknopf	Pomo
	Complementi	Complements	Compléments	Zubehör	Complementos
	Dispositivi antieffrazione	Sets against window breaking	Set de protection anti bris de glace	Sichereitssätze	Dispositivo antivándalico
	Fermaporta	Door stopper	Butées	Türpuffer	Topes de puerta
	Chiavi	Keys	Clés	Schlüssel	Llaves
	Bocchette	Escutcheons	Couvre serrure	Schlüsselrosetten	Bocallave
	Bocchette strette	Oval escutcheons	Couvre serrure oval	Oval-Schlüsselrosetten	Cerradura ovalada
Rosette	Roses	Rosettes	Drückerrosetten	Rosetas	
Rosette strette	Oval roses	Rosettes ovales	Oval-Drückerrosetten	Rosetas ovaladas	

Concept and graphic design

**Colombo Design**

Printed in Italy

**05/17**

Colombo Design si riserva di apportare ai propri prodotti ogni modifica estetica e tecnica che a suo insindacabile giudizio ritenga necessaria.

Il presente catalogo è tutelato dalla legge sui diritti di autore di esso è quindi proibita ogni riproduzione, totale o anche parziale.

Il listino prezzi può avere frequenze di aggiornamento superiori al catalogo generale, costituisce quindi lo strumento di consultazione più aggiornato.

Le textures ed i colori dei materiali e delle finiture hanno valore indicativo in quanto soggetti alle tolleranze dei processi di stampa.

Le misure indicate sono espresse, se non specificato diversamente, in millimetri.

Colombo Design reserves the right to modify parts of its collection range whenever necessary without previous notice.

This catalogue is protected by the Italian copyright laws. No part of this catalogue may be reproduced in any form or by any means

The price-list has a printing frequency higher than the general catalogue, therefore it is the most up-dated consulting tool.

The textures and colours of materials and finishes are not binding as they depend on printing colour tolerances.

All measures mentioned herein are stated in millimeters, if not differently specified.





COLOMBO DESIGN S.p.A.  
Via Baccanello, 22  
24030 Terno d'Isola (BG) Italia  
☎ 035.49.49.001  
Fax 035.90.54.44

Export Office  
☎ (+39) 035.90.54.75  
Fax (+39) 035.49.40.257

Internet: <http://www.colombodesign.it>  
e-mail: [info@colombodesign.it](mailto:info@colombodesign.it)

follow us on



0 5 1 7 1 2 3 3 7 2 3