

Notes:

- 1) To stamp TopSlide Logo, order number & part # on inner member
- 2) Pull out force $25 \pm 3N$
- 3) Regular grease

註釋:

- 1) 內軌請打上客人商標TopSlide、型號758及訂單號TSDK XXXX
- 2) 縮口拉力控制在 $25N \pm 3N$
- 3) 使用油脂HP6021-A167M

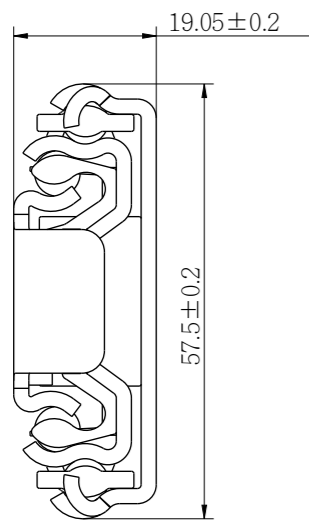

比例 1:1

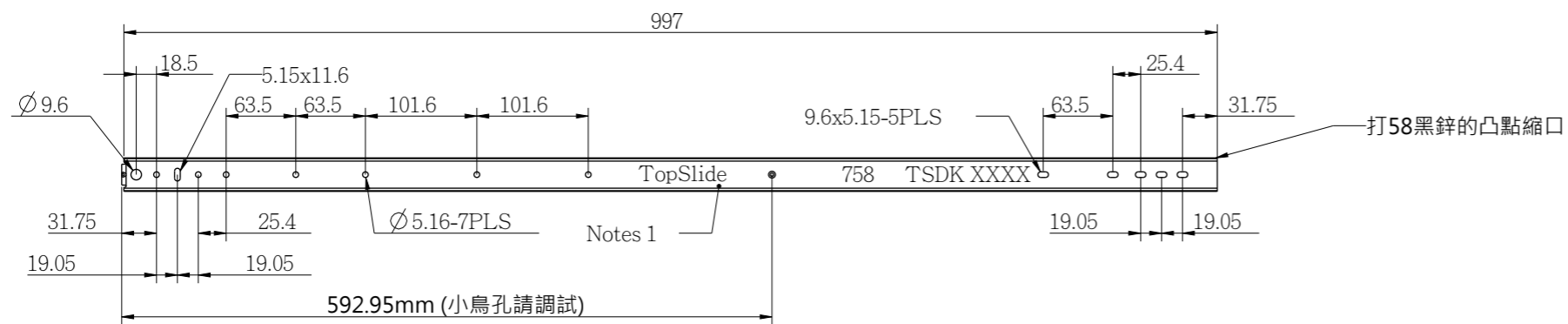
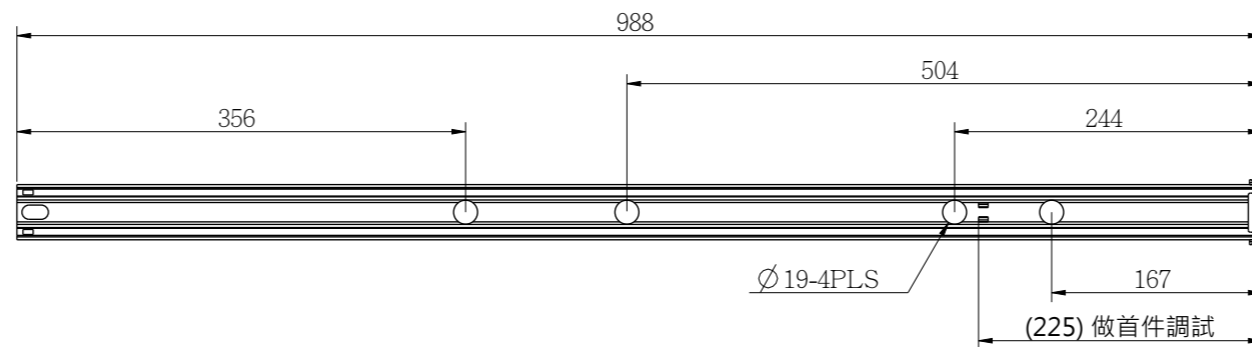
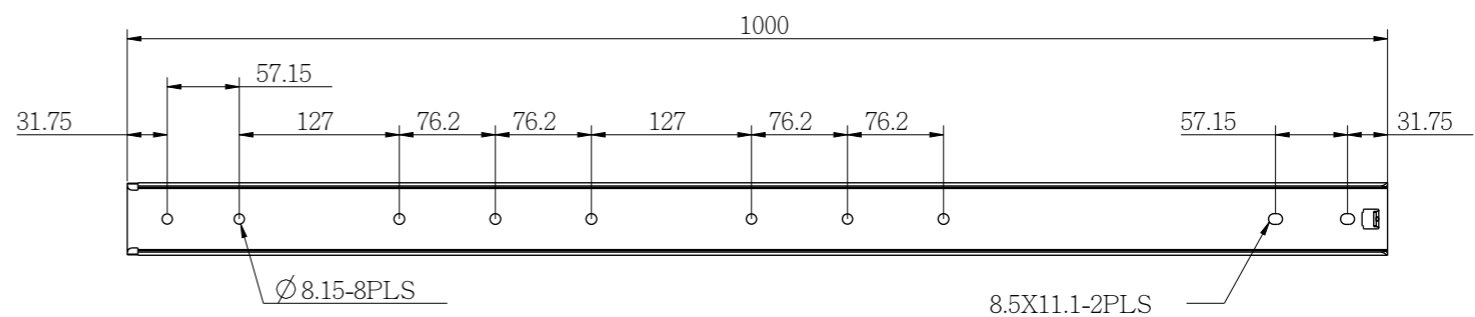

<h1>TopSlide</h1> <p>INTERNATIONAL</p>		wildfire_data\TRC\TopSlide\58\758\758-1000_A1\758-1000.drw			
		比例 Scale	0.167 & 1:1	厚度 Thickness	2.0\2.0\2.0
客戶 Customer	-			圖紙大小 Sheet Size	A4
產品型號 Part No.	758-1000			第1張 共1張 SHEET 1 OF 1	版本 Rev.
繪圖 Dwn by	Jackie	2015/3/16	產品圖號 Draw No.		
審核 Ckd by			圖紙說明 Description	公制1000mm長	

A1	Jackie	外軌珠條改為361+156 mm	2015/3/15
A0	Jackie	758 new hole pattern for approval	2013/3/28
Rev.版本	Name 姓名	Description 描述	Date 日期