

LUNCH+39

ISTRUZIONI DI MONTAGGIO ASSEMBLY INSTRUCTIONS

MODELLO
MODEL:

411/39.1100.25

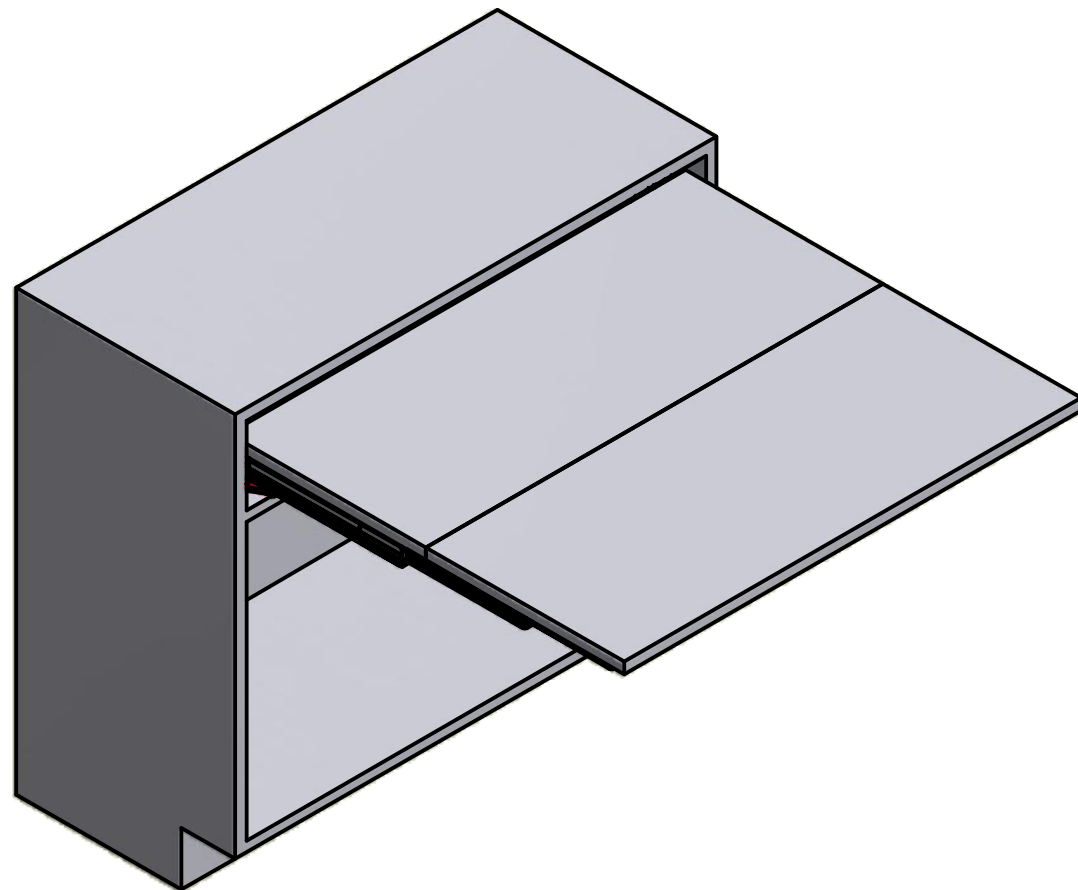





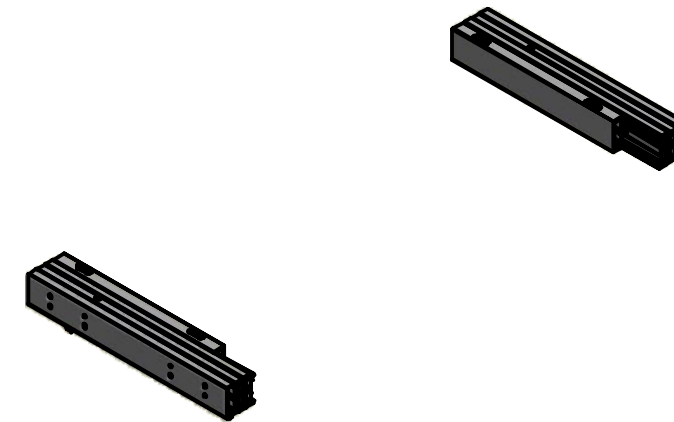

CONTENUTO DELLA CONFEZIONE INCLUDED IN THE PACKAGING

GUIDE
SLIDES



SACCHETTO ACCESSORI - ACCESSORIES

-  A. Vite TPS M6x60 - Screw M6x60 TPS (x 4)
-  B. Vite TCCE M6x12 - Socked head cap screws M6x12 (x 8)
-  C. Bussola in ottone mm 12x8 M6 - Brass bush 12x8 M6 (x 12)
-  D. Perno - Pin (x 2)
-  E. Chiave esa. da 5 - n° 5 Allen key (x 1)
-  F. Chiave esa. da 4 - n° 4 Allen key (x 1)

DIMENSIONI GENERALI MOBILE GENERAL CABINET DIMENSIONS

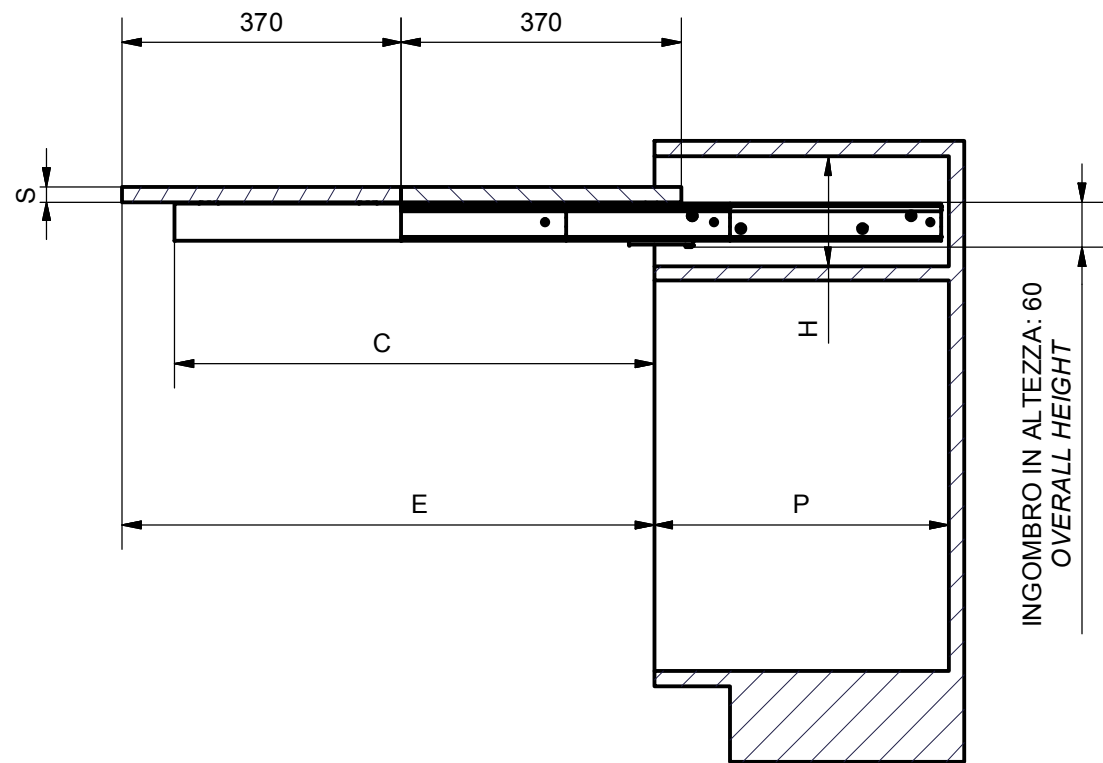

DIMENSIONE - DIMENSION	SIMBOLO - SYMBOL	-
LUCE VERTICALE - VERTICAL FREE SPACE	H	MIN: 120 mm
PROFONDITA' INTERNA - INTERNA FREE SPACE	P	MIN: 390 mm
LARGHEZZA INTERNA MODULO - CABINET INTERNAL WIDTH	L	MAX: 1300 mm
SPESSORE SPALLA - SIDE THICKNESS	S1	15-20 mm
SPESSORE PIANI - PLANES THICKNESS	S	15-20 mm
LARGHEZZA PIANI - PLANES WIDTH	Z	L-5 mm
APERTURA PIANI - OPENING PLANES	E	705 mm (MAX: 790 mm)
APERTURA MECCANISMO - OPENING MECHANISM	C	835 mm (MAX: 720 mm)

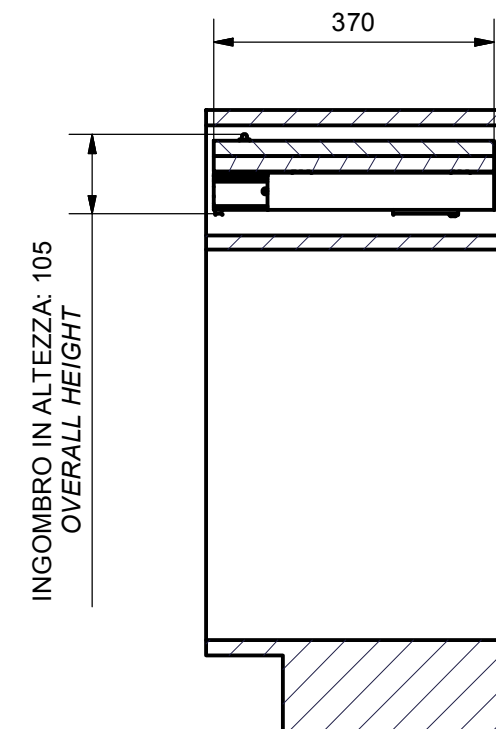
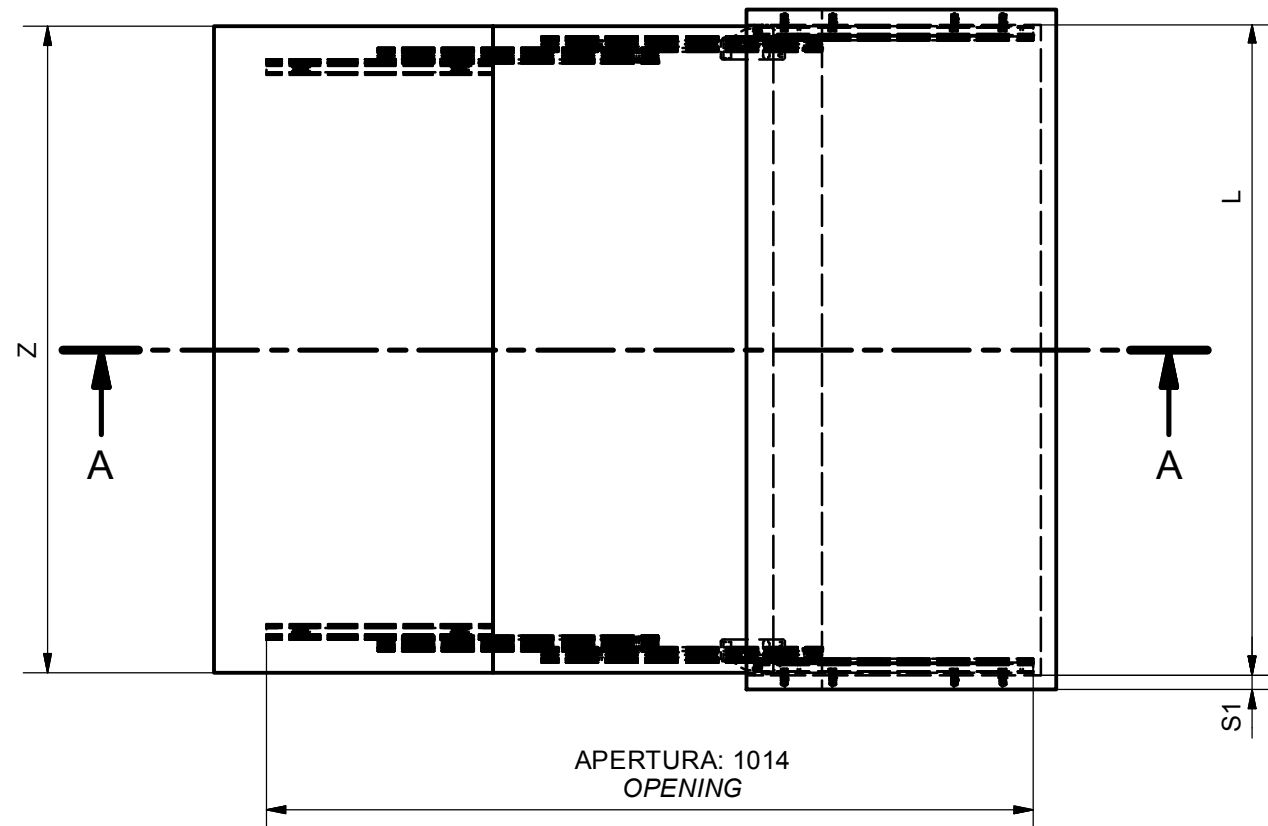

POSIZIONE FORI FISSAGGIO
MECCANISMO
HOLES FOR MECHANISM
POSITION

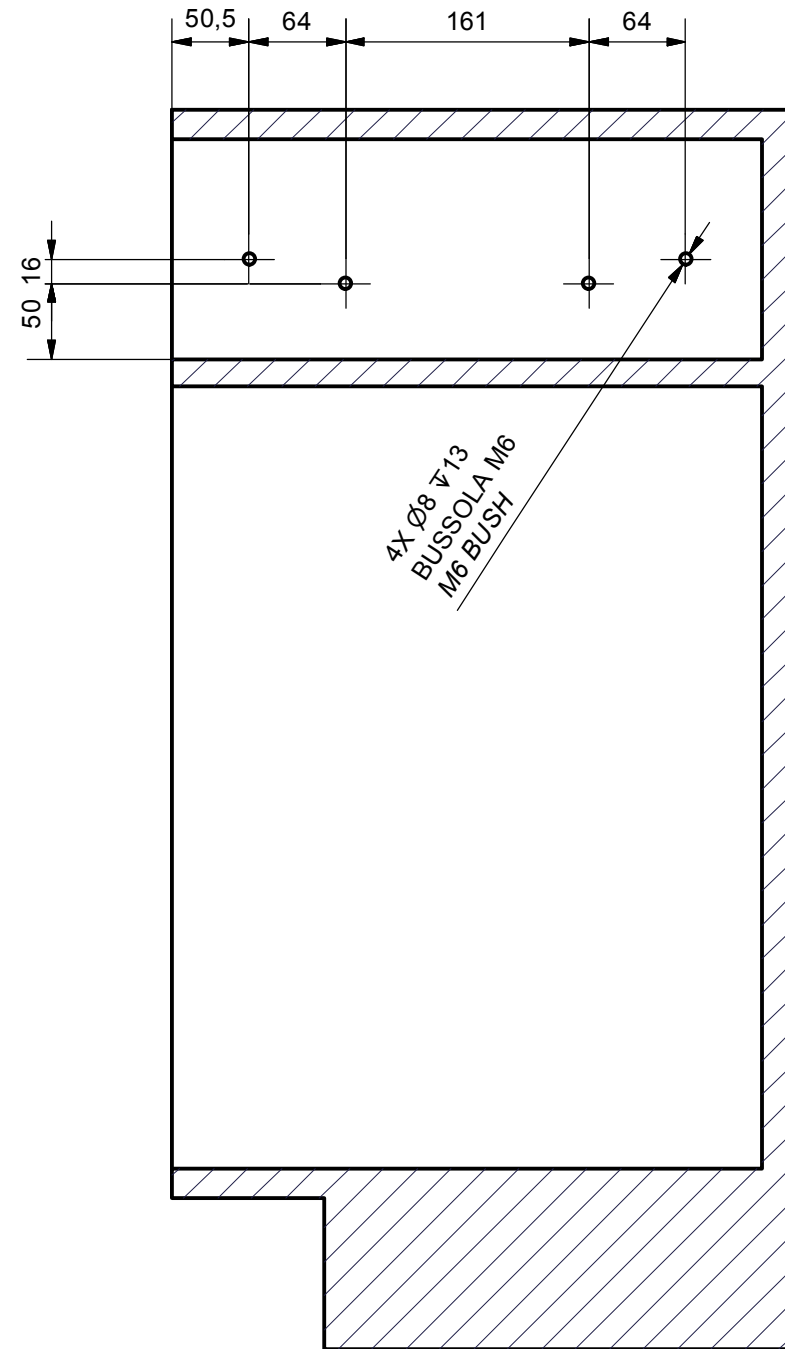

DIMENSIONI PIANETTI
PLANES DIMENSIONS

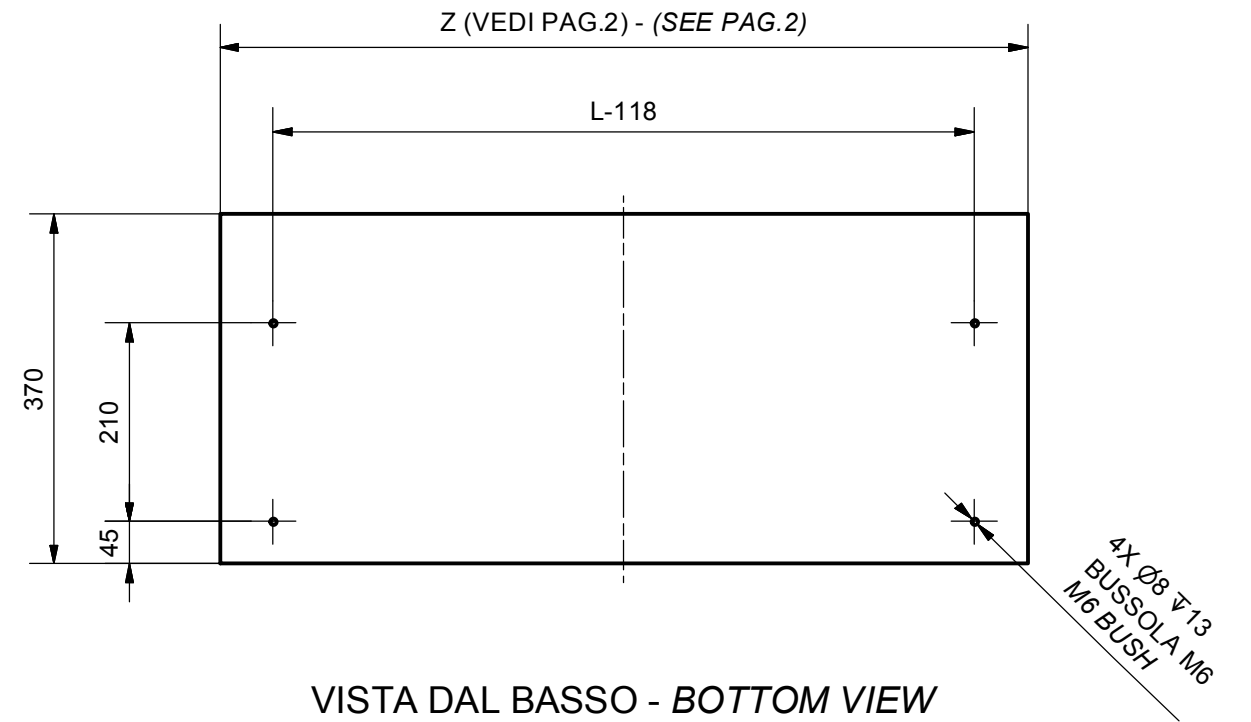

VISTA DAL BASSO - BOTTOM VIEW

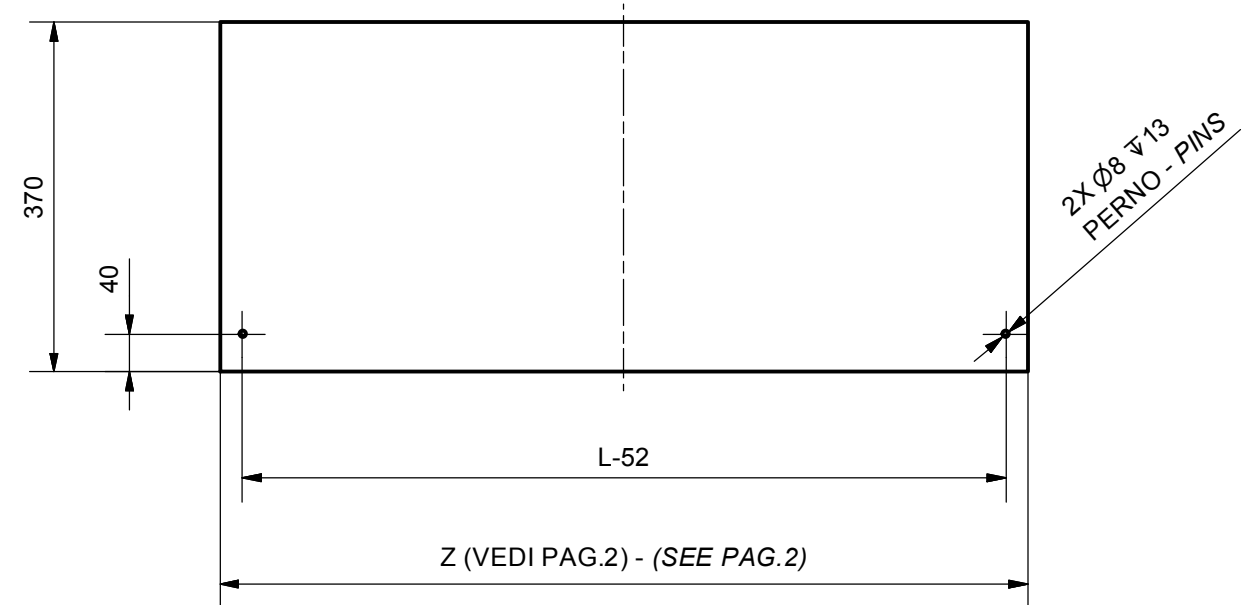

- C. Bussola in ottone mm 12x8 M6 - Brass bush 12x8 M6 (x 12)
- D. Perno - Pin (x 2)

MONTAGGIO DEL MECCANISMO SUL MOBILE MOUNTING OF THE MECHANISM ON THE CABINET

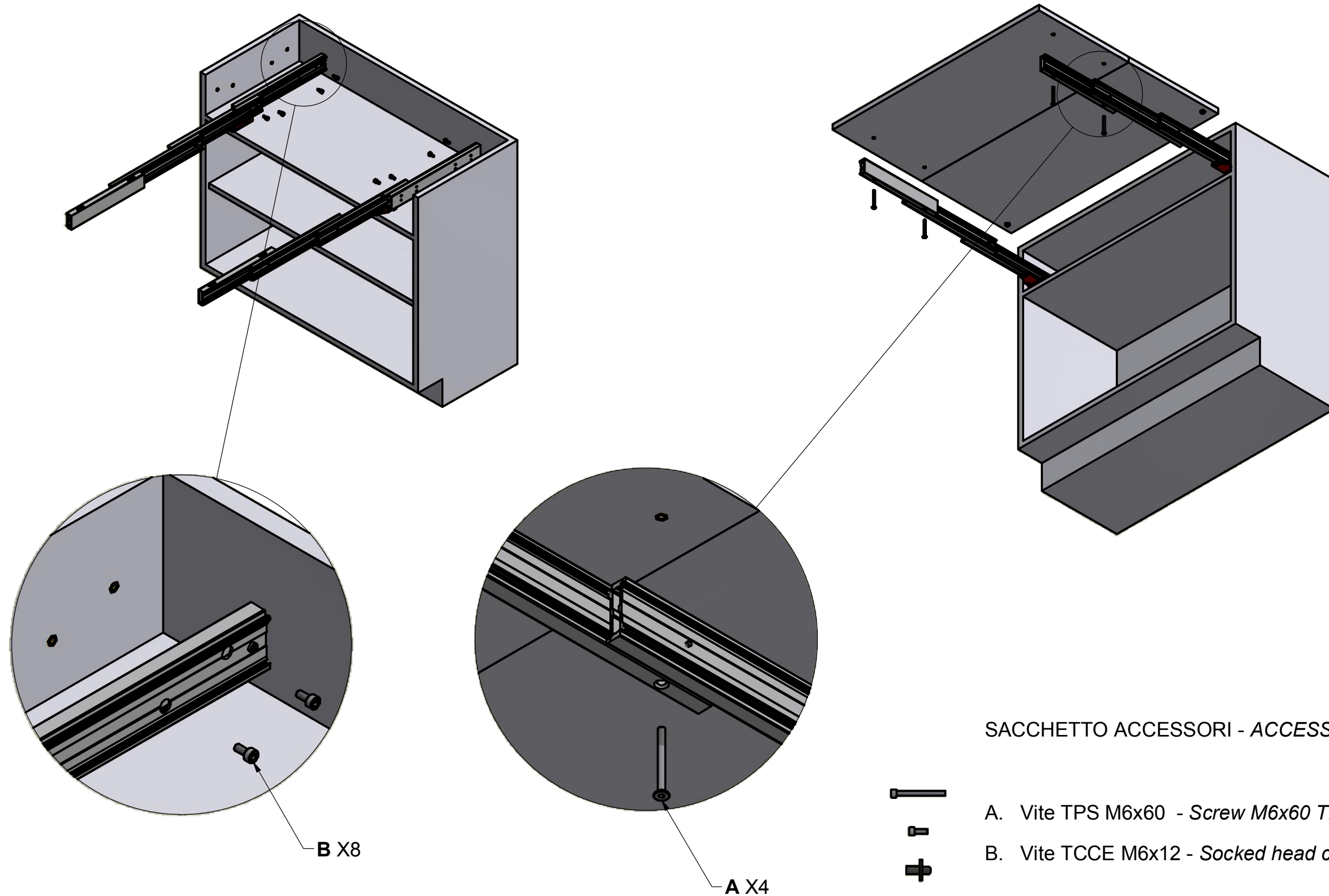

SACCHETTO ACCESSORI - ACCESSORIES

A. Vite TPS M6x60 - Screw M6x60 TPS (x 4)

B. Vite TCCE M6x12 - Socked head cap screws M6x12 (x 8)

SEQUENZA DI FUNZIONAMENTO

FUNCTIONING STEPS

CHIUSO
CLOSED

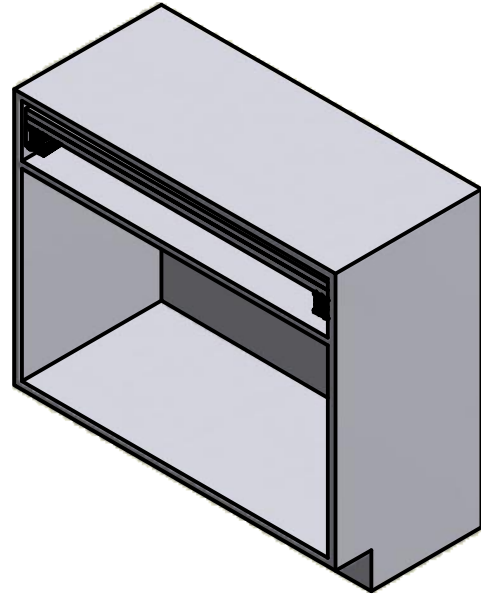

ESTRAZIONE GUIDE
SLIDES OPENING

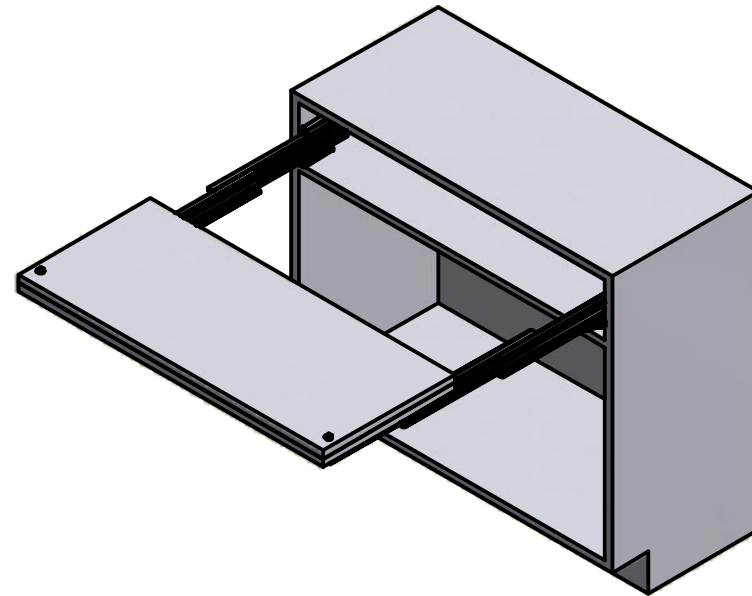

ROTAZIONE PIANETTO
PLANE TILTING

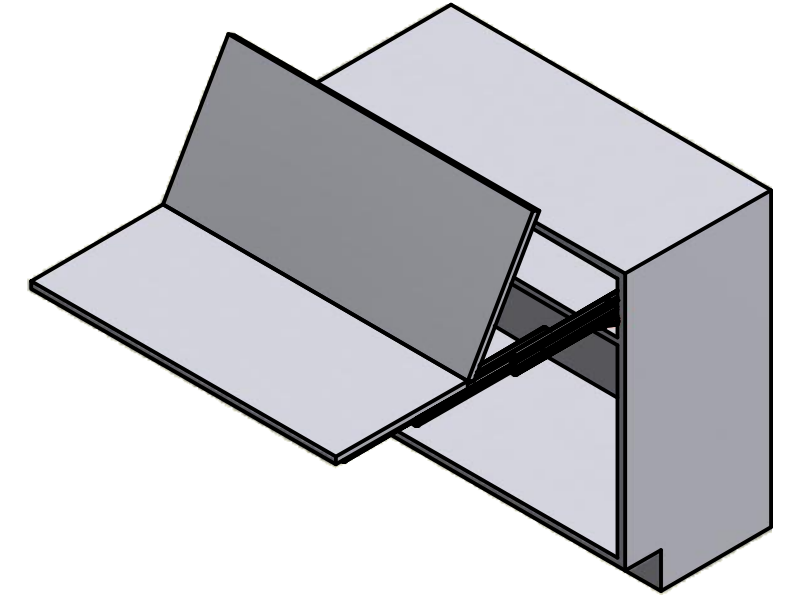

PER BLOCCARE I PIANI SPINGERE VERSO L'INTERNO IN MODO CHE IL PERNO ENTRI NELLA SUA SEDE

TO BLOCK THE PLANES PUSH TOWARDS THE CABINET SO THAT THE PIN ENTERS IN HIS SLOT

APERTURA MASSIMA
MAX OPENING

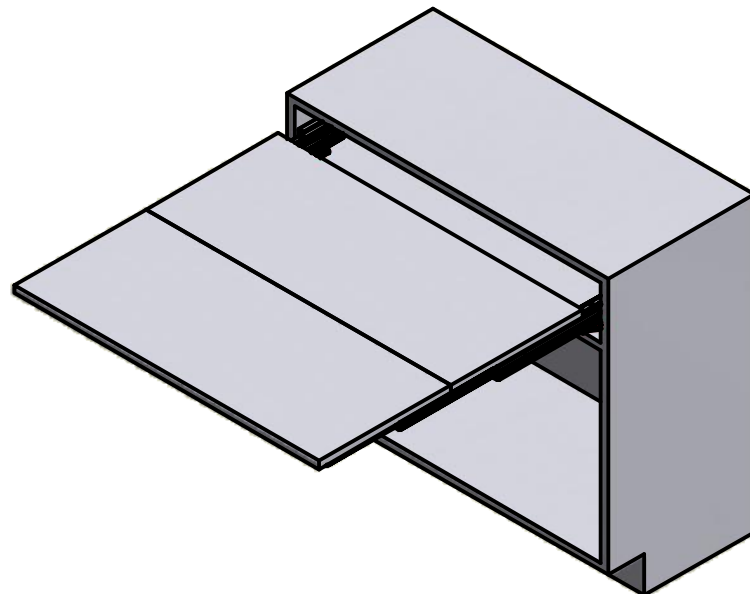

APERTO
OPEN

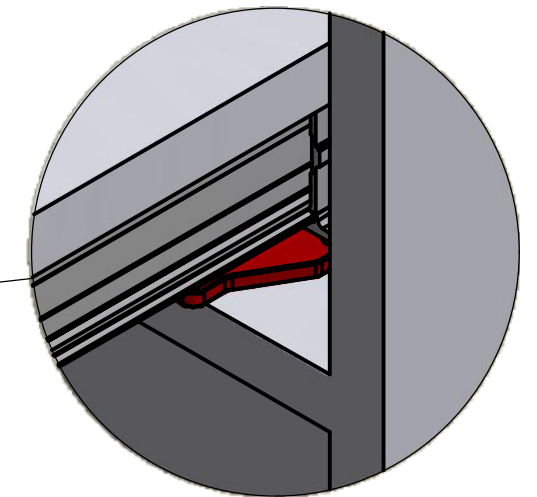
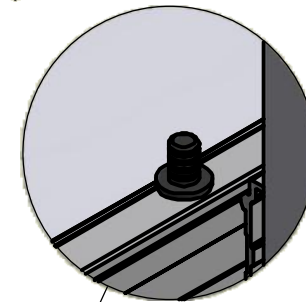
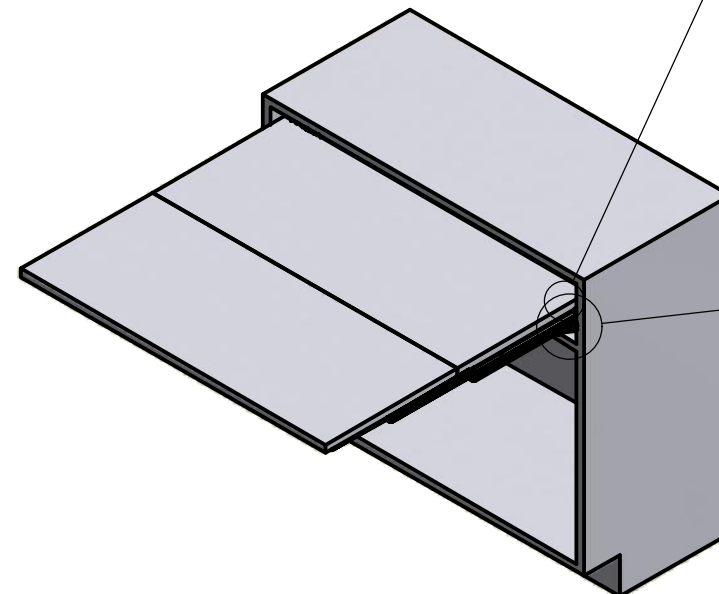

SPINGERE VERSO INTERNO LA LEVA ROSSA PER CHIUDERE IL MECCANISMO
PUSH THE RED LEVER TO CLOSE THE MECHANISM