

VN 2927/120 Compact

for unrebated heavy-duty doors with thin block frames



Product features

- for unrebated heavy-duty doors
- for block and blind frames
- with receiver in the door leaf
- with comfortable 3D adjustment (side +/- 3,0 mm, height +/- 3,0 mm, compression +/- 1,0 mm)
- internal torsion-proof pin
- concealed, maintenance -free axial-radial slide bearings

Technical details

Attributes	Value
Knuckle length	120,0 mm
Knuckle diameter	20,0 mm
Cutter diameter	24,0 mm
Material thickness	3,5 mm

Note

The load capacity mentioned above refers to the use of 2 hinges per door leaf (1 x 2 m), for detailed information please look at the chapter "technical information".

Also available with security pin (MSTS).

Quality marks



Certification CE



Certification IFT

Classification key

4	7	6	1	1	* ₆	1	13
---	---	---	---	---	----------------	---	----

⁶ depending on the finish

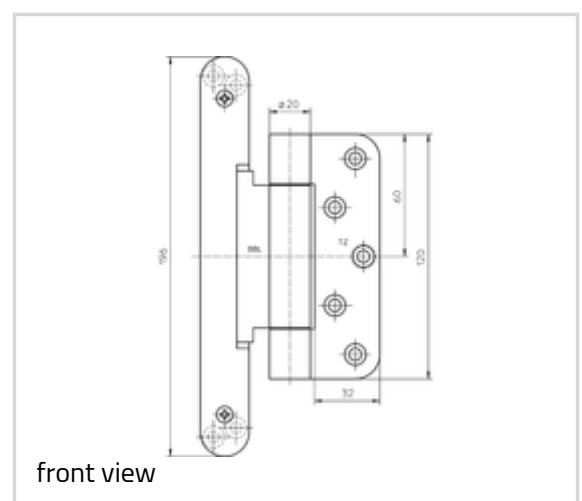

VARIANT VN - VN 2927/120 Compact

A reinforcing dowel 12 x 50 mm per hinge is recommended when the door is subject to heavy usage.

Screws 4,5 x 50,0 mm can be used as an alternative for lowering the depth.

Suitable for

Universal milling frame

Template 5 250354 5

frame

Template 5 250697 5

door - step 1

Template 5 250698 5

door - step 2

Template 5 250699 5

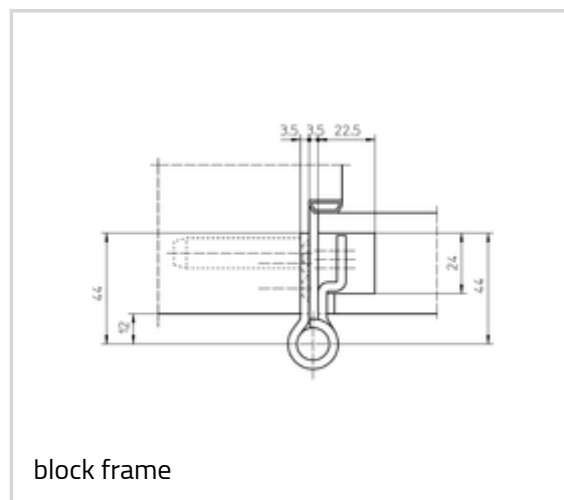

Combinations

VN 2900/120

Function range



fire resistance



smoke resistance

Item

Finish(es)	037-satin chromed/F1
OF-NR.	037
VPE	pack of 2
DIN	DIN right and left hand
Item No.	5 040770 0 03702
EAN	4015471103361
Finish(es)	040-Satin Stainless Steel
OF-NR.	040
VPE	pack of 2
DIN	DIN right and left hand
Item No.	5 040770 0 04002
EAN	4015471103453

